

**GENERAL SPECIFICATIONS:**

- Maximum Flow: 150 GPM (No minimum flow requirement)
- Maximum Pressure: 125 PSI (Higher pressure models are available).
- Maximum Temperature: 135° F (Higher temperature models are available).
- Screen Surface Area 200 Sq. In.

**MATERIALS:**

- Housing: 316 Stainless
- Gasket: EPDM standard (other compounds available)
- Screen: 5/64" Perforated, 316 Stainless.
- Clamp: 301, 302 or 304 Stainless.

**SCREEN OPTIONS:**

- Multiple screen mesh and perforated sheet sizes available. (See product catalog for samples)

**NOTES:**

- 1- Dimensions are for informational purposes only and are subject to change.
- 2- 37" Overall Height is required for filter element removal.

Conical Filter Element  
(See Specifications)

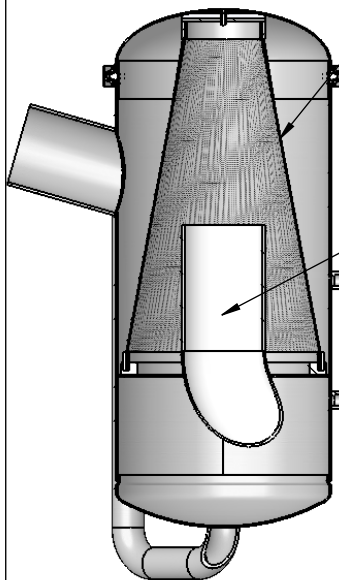

SECTION A-A

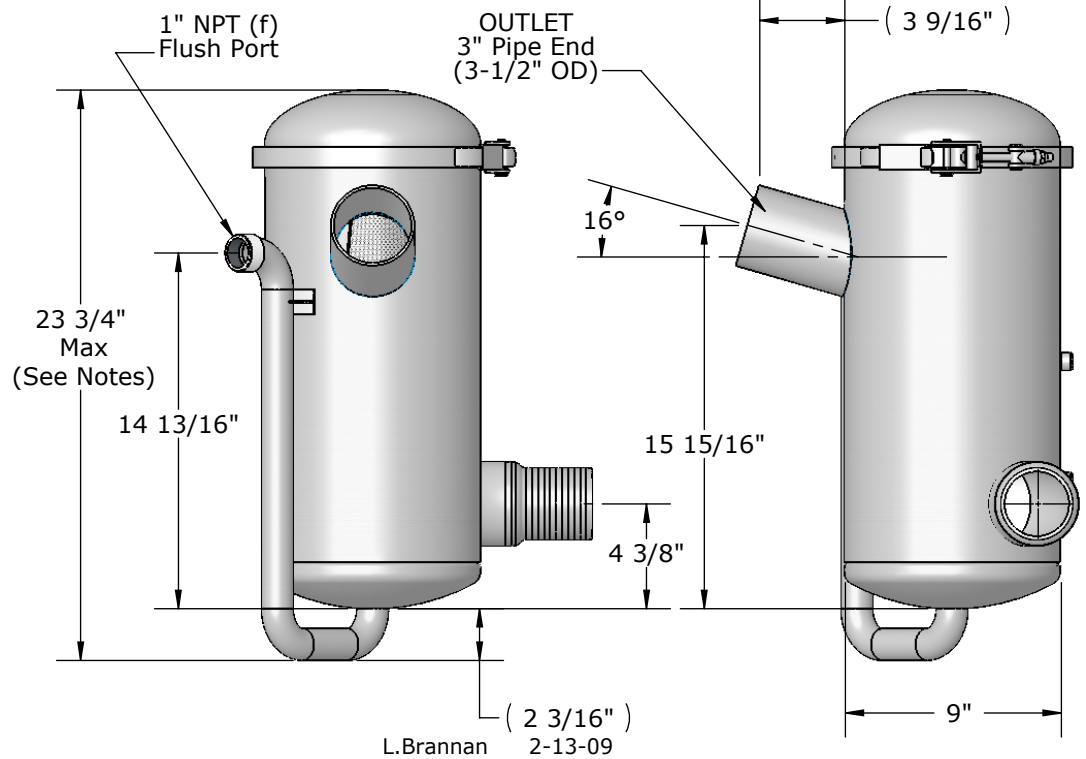
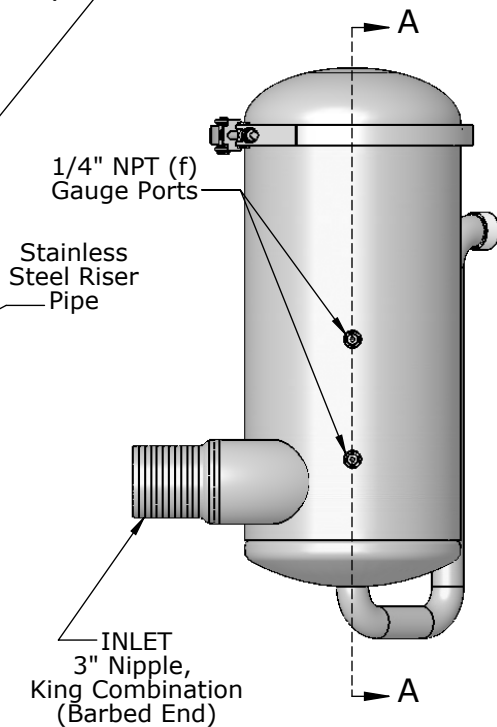

Rev A

**PRODUCT SPECIFICATION**

**MILLER-LEAMAN INC.**

800 Orange Ave. Daytona Beach FL 32114

DRAWN			
CHECKED			
ENG APPR.			
MKT APPR.	SHEET 1 OF 1		

TITLE  
**Thompson Strainer  
MLS-3-T316-CADENZA B**

L.Brannan 2-13-09