

GENERAL SPECIFICATIONS:

- Maximum Flow: 200 GPM (No minimum flow requirement)
- Maximum Pressure: 125 PSI
- Maximum Temperature: 135° F
- Screen Surface Area 200 Sq. In.

MATERIALS:

- Housing: 316 Stainless
- Gaskets: EPDM
- Screen Mesh: 5/64" perforated sheet backup, 316 Stainless

SCREEN OPTIONS:

- Multiple screen mesh and perforated sheet sizes available. (See product catalog for samples)

NOTES:

- 1- Dimensions are for informational purposes only and are subject to change.
- 2- Overall Height of 36 3/8" required for Filter Element Removal.

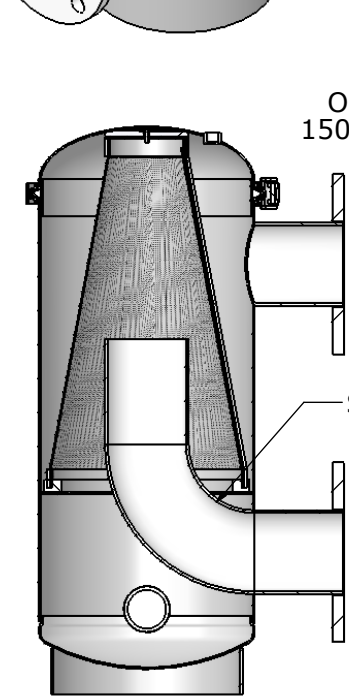

SECTION A-A

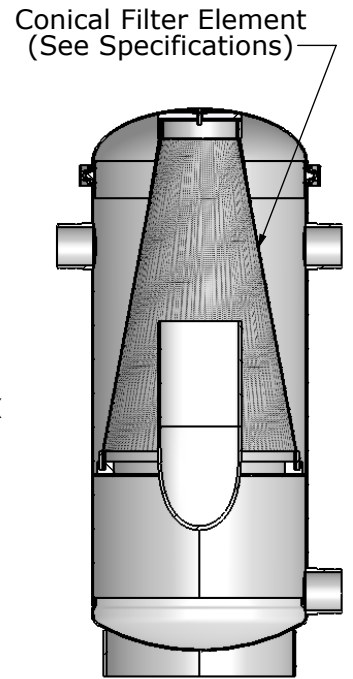
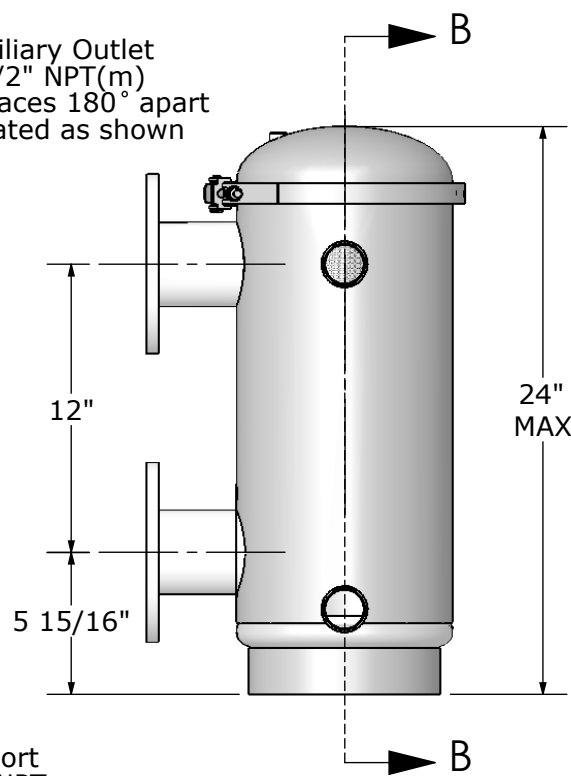
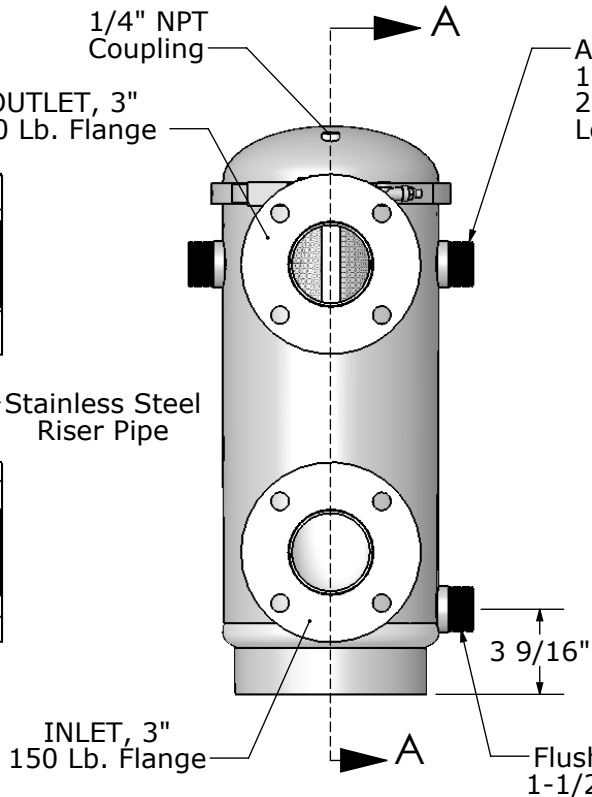

SECTION B-B

PRODUCT SPECIFICATION

MILLER-LEAMAN INC.

800 Orange Ave. Daytona Beach FL 32114

DRAWN	L.Brannan	1/8/08
CHECKED		
ENG APPR.		
MKT APPR.		
SHEET 1 OF 1		

TITLE

**Thompson Strainer
MLS-3-T316-MOD7**