



**MILLER-LEAMAN, INC.**  
800 Orange Avenue / Daytona Beach, FL 32114  
(386) 248-0500 / (386) 248-3033 FAX  
Email: [sales@millerleaman.com](mailto:sales@millerleaman.com)  
Web Site: [www.millerleaman.com](http://www.millerleaman.com)

Record in the space below the serial number of your filter. The serial number is located on the data plate decal on the face of the housing.

**SERIAL #** \_\_\_\_\_

### IMPORTANT

Please make certain that persons who are to use this filter thoroughly read and understand these instructions prior to operation. Should you have any questions regarding the operation of this filter, please call (386) 248-0500 and ask to speak with one of our customer service representatives, or email us at [sales@millerleaman.com](mailto:sales@millerleaman.com).

# HELIX FILTER

MTD SERIES — HELIX DISC FILTER  
MTS SERIES — HELIX SCREEN FILTER/STRAINER  
OWNER'S MANUAL  
INSTALLATION AND OPERATION GUIDE

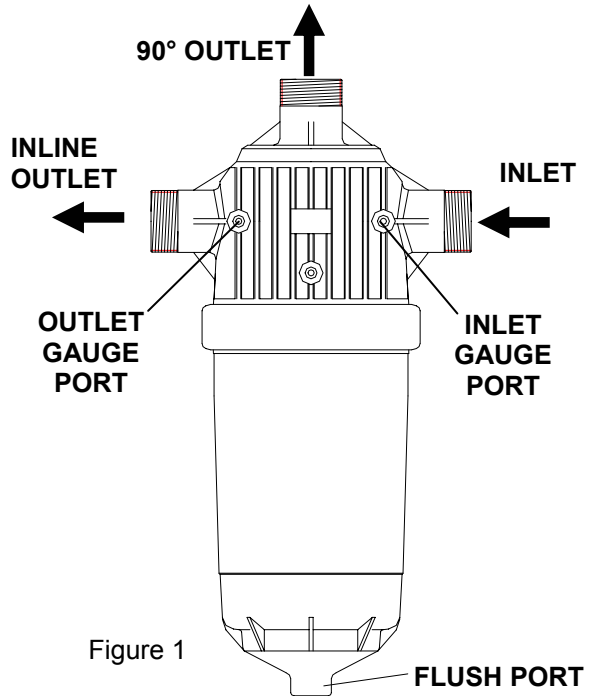

Figure 1

## I. SAFETY CONSIDERATIONS

Safety precautions are essential when any filtration equipment is involved. These precautions are necessary when using, storing, and servicing your filter. If safety precautions are overlooked or ignored, personal injury or product damage may occur.

Your filter was designed for specific applications. It **should not** be modified and/or used for any application other than originally specified. If there are any questions regarding its application or installation, write or call Miller-Leaman, Inc.

**NOTE CONCERNING CLEAR POLYCARBONATE COVERS:** Clear covers should be used for demonstration and intermittent use only. Clear covers will degrade in sunlight. If any cracks or fractures are observed in the clear cover discard cover immediately.

### ALWAYS OBSERVE THE FOLLOWING PRECAUTIONS:

1. Read this manual carefully. Consider the applications, limitations, and the potential hazards specific to your filter.
2. **Absolutely, under no conditions, should the filter clamp/lid or pressure gauges be removed while the filter is pressurized.**
3. Units with damaged or missing parts should **never** be operated. Contact our customer service representatives for replacement parts.
4. Pressure relief valves of a sufficient size and volume should be installed upstream of the inlet and downstream of the outlet of the filter. They should be set to relieve pressure at 1.2 times your maximum operating pressure (not to exceed the maximum rated pressure of 125 PSI). This will help to prevent injury and damage to the filter housing and filter disc/screen cartridge if severe stoppage or water hammer occurs.

**AT NO TIME SHOULD THE INTERNAL PRESSURE EXCEED THE MAXIMUM RATED PRESSURE FOR YOUR FILTER**

## II. INSTALLATION

Please review the following checklist. When all tasks are complete the filter is ready to be used.

1. Your Helix Filter is equipped with (1) inlet and (2) outlet connections. Choose either the In-Line outlet or the 90 degree configuration and terminate the outlet port not being used with the supplied pipe cap. **The preferred orientation of installing the Helix Filter is with the flush port pointing downward (fig. 1); however, the filter can also be installed with the 3/4" connection pointing upward.**

2. Fasten inlet and outlet connection securely to system piping. Arrows on the filter housing clearly depict flow direction.
3. We recommend the installation of a quick pressure relief valve upstream of the inlet and downstream of the outlet of the filter. Set the valves to relieve pressure at 1.2 times your maximum operating pressure (not to exceed the maximum rated pressure of 125 PSI). Installation of these valves will prevent injury and damage to the filter if severe clogging or water hammer occurs.
4. Install a valve on the flush port located at the bottom of the removable filter lid (fig. 2).
5. Install threaded pressure gauges into the inlet and outlet gauge ports located on the side of the filter (E & F, fig. 2).
6. Before start up, make sure the filter lid and stainless steel band-clamp are securely fastened.

### III. FILTER OPERATION

Once installed, dirty liquid flows into the filter housing through the inlet connection and will pass through the Helix Element which creates a centrifugal action. This action spins the particles away from the filter media minimizing the manual cleaning frequency. As particles are spun down to the base of the filter, they are flushed via the 3/4" female threaded flush port connection. The dirty water passes from the outside to the inside of the filtration cartridge which will capture the remaining contaminants in the water. After passing through the filtration cartridge the filtered water flows upward and exits the filter through one of the outlets. The outlet not being used is terminated with a threaded cap.

**(Note: After operation, open the flush port to allow the water/liquid contained in the filter body to drain. If there is non-compatible chemical content in the water, it may degrade or swell the plastic. Also, in winter months, the water may freeze and expand putting unnecessary stress on the filter body.)**

If the inlet pressure gauge displays a pressure reading 10-15 PSI greater than the outlet pressure gauge, flow to the filter must be terminated and the filtration cartridge must be inspected as per section IV, Filtration Cartridge Maintenance.

**CAUTION: DO NOT OPEN UNDER PRESSURE. REMOVE ALL PRESSURE FROM THE FILTER BY SHUTTING THE SYSTEM DOWN OR**

### IV. FILTRATION CARTRIDGE MAINTENANCE

**ISOLATING THE FILTER FROM THE OPERATING SYSTEM. OPEN DRAIN/FLUSH PORT TO RELIEVE PRESSURE AND DRAIN LIQUID FROM FILTER HOUSING. DO NOT ATTEMPT TO SERVICE THE FILTER UNTIL THE PRESSURE IS RELIEVED.**

**Step 1:** Terminate flow to the system and open flush port. Pressure gauges mounted on the filter housing must read zero.

**Step 2:** Unlatch the band clamp assembly and remove the filter lid.

**Step 3:** Remove the filter cartridge from the filter body. The filtration cartridge seats tightly into the filter body. If necessary, rock the cartridge gently from side to side to facilitate removal.

**Step 4:** Rinse the exterior of the cartridge to remove any loose debris on the exterior surface of the discs/screen.

**Step 5:** Cleaning instructions for the Helix HD and HS series filters. (See Below)

#### MTD Series – DISC Filter

Unscrew the threaded wing bolt until bolt and cartridge cover plate are loose. Do not remove the wing bolt from the filtration cartridge. The filtration discs will be loose and can freely move on the filtration cartridge frame. Rinse the filtration discs until all contaminants are removed. Restack the discs onto the cartridge frame, position the cover plate and retighten the threaded wing bolt, hand tighten only. **IMPORTANT: Be sure all particulate has been thoroughly rinsed from between the discs. Particles caught between discs could affect filtration integrity.**

**Step** o-ring on the cartridge into the filter body.

**Step 7:** Securely fasten the filter lid to the housing with the stainless steel band clamp.

#### MTS Series – SCREEN Filter

Unscrew the threaded wing bolt until bolt and cartridge cover plate are loose. Remove the wing bolt from the filtration cartridge and the screen cartridge can be removed from the filtration cartridge frame. Use a nylon brush while rinsing to remove debris/particles from the outside of filtration screen. Replace the screen back onto the cartridge frame, reposition the cover plate and retighten the threaded wing bolt, hand tighten only.

**6:** Reposition the filtration cartridge into the filter body. Push firmly to seat the

### V. INFORMATION CONCERNING WATER HAMMER

#### **WHAT IS WATER HAMMER?**

Water hammer is a phenomenon that can occur in fluid systems with long pipes between the fluid source and the fluid system outlet. The term itself refers to the sound made when water hammer occurs which resembles banging a hammer on a long pipe. Water hammer is a rapid change of pressure caused by a rapid change in velocity. When the velocity is changed a pressure wave that travels at the speed of sound is initiated and travels in the upstream direction until it reaches some stationary energy level, like a reservoir. A rarefaction wave (at the pressure of the water source) then travels downstream at the same speed. If the flow has been shut off down-stream the pressure wave impacts the blockage and the pressure in the entire system is raised very rapidly.

### **WHAT CAUSES WATER HAMMER?**

Any action that can cause a rapid change in the velocity of the flow can initiate water hammer - closing a downstream valve, pipe fracture, pump stoppage, etc. The critical time for which a valve may be closed depends on the length of piping between the valve and the source reservoir. The longer the distance the slower the valve may be shut to cause a water hammer. Typically for short lengths of pipe (below 500 ft) the critical time is less than 1/10 of a second.

### **WHAT CAN WATER HAMMER DO?**

Pressure spikes from water hammer can raise fluid pressures to very high values (in excess of 1000 PSI depending on the situation). Such pressure spikes can result in mechanical failures such as broken valves, pipes, filters, joints, etc. Water hammer does not have to occur fully to raise the pressure. A partial hammer can occur that raises the pressure to a certain percentage of the theoretical maximum. The *Helix Filter* is rated to a maximum pressure of 125 PSI. A water hammer pressure spike that raises the pressure higher than the maximum rated pressure may result in injury and/or damage to filter housing and filter cartridge.

### **FAILURE TO FOLLOW INSTRUCTIONS AND WARNINGS CAN RESULT IN SERIOUS BODILY INJURY.**

### **WHAT CAN I DO TO PREVENT WATER HAMMER?**

There are precautions that can be taken to prevent or decrease the effect of water hammer. A pressure relief valve that leads to a surge tank or accumulator may protect other key components from water hammer. A close adherence to operational policies will also help prevent valves or pumps from being accidentally shut off thereby causing a water hammer. A close examination of a system will inform you where potential hazards exist.

## **VI. LIMITED WARRANTY**

### **1) Duration:**

Filter Disc/Screen Cartridge: Ninety days from the date of purchase by the original purchaser (other than for purposes of resale).

Filter Housing & all other components: One year from the date of purchase by the original purchaser.

### **2) Who gives this warranty (Warrantor)**

Miller-Leaman Incorporated

800 Orange Avenue; Daytona Beach, FL 32114

### **3) Who receives this warranty (Purchaser):**

The original purchaser (other than for purposes of resale) of the Miller-Leaman product.

### **4) What products are covered by this warranty:**

Any Miller-Leaman *Helix* housing and filter cartridges manufactured or sold by the warrantor.

### **5) What is covered under this warranty:**

Defects on materials and workmanship, which occurs within the duration of the warranty period.

### **6) What is not covered under this warranty:**

**A)** Implied warranties, including those of merchantability and fitness for a particular purpose, are limited to one year from the date of original purchase. Some states do not allow limitations on how long an implied warranty lasts, so the above limitations may not apply to you.

**B)** Any incidental, indirect, or consequential loss, damage, or expense that may result from any defect, failure, or malfunction of the Miller-Leaman product. Some states do not allow the exclusion or limitation of incidental or consequential damages, so the above limitation or exclusion may not apply to you.

**C)** Any failure that results from an accident, purchaser's abuse, neglect, or failure to operate the product in accordance with the instructions provided in the owner's manual supplied with the product.

**D)** Items or service that are normally required to maintain the product, i.e. gaskets.

### **7) Responsibilities of warrantor under this warranty:**

Repair or replace, at warrantor's option, products or components which have failed within the duration of the warranty period.

### **8) Responsibilities of purchaser under this warranty:**

**A)** Deliver or ship the warranted product to the Miller-Leaman manufacturing facility. Freight costs, if any, must be borne by the purchaser.

**B)** Use reasonable care in the operation and maintenance of the product as described in the owner's manual.

### **9) When the warrantor will perform repair or replacement under warranty.**

**A)** Repair or replacement will be scheduled and serviced according to the normal workflow at the manufacturing facility, and depending on the availability of replacement parts.

**B)** If the purchaser does not receive satisfactory results from the product repair or replacement, the purchaser shall contact Miller-Leaman immediately.

**NOTE: THIS WARRANTY IS VOID IN THE EVENT THE PURCHASER FAILS TO COMPLY WITH ANY ONE OF THE REQUIREMENTS FOR INSTALLATION AND USE OUTLINED OR SET FORTH IN THIS MANUAL AND MILLER-LEAMAN INCORPORATED ASSUMES NO LIABILITY WHAT-SO-EVER.**

**This Limited Warranty gives you specific legal rights and you may also have other rights which vary from state to state.**

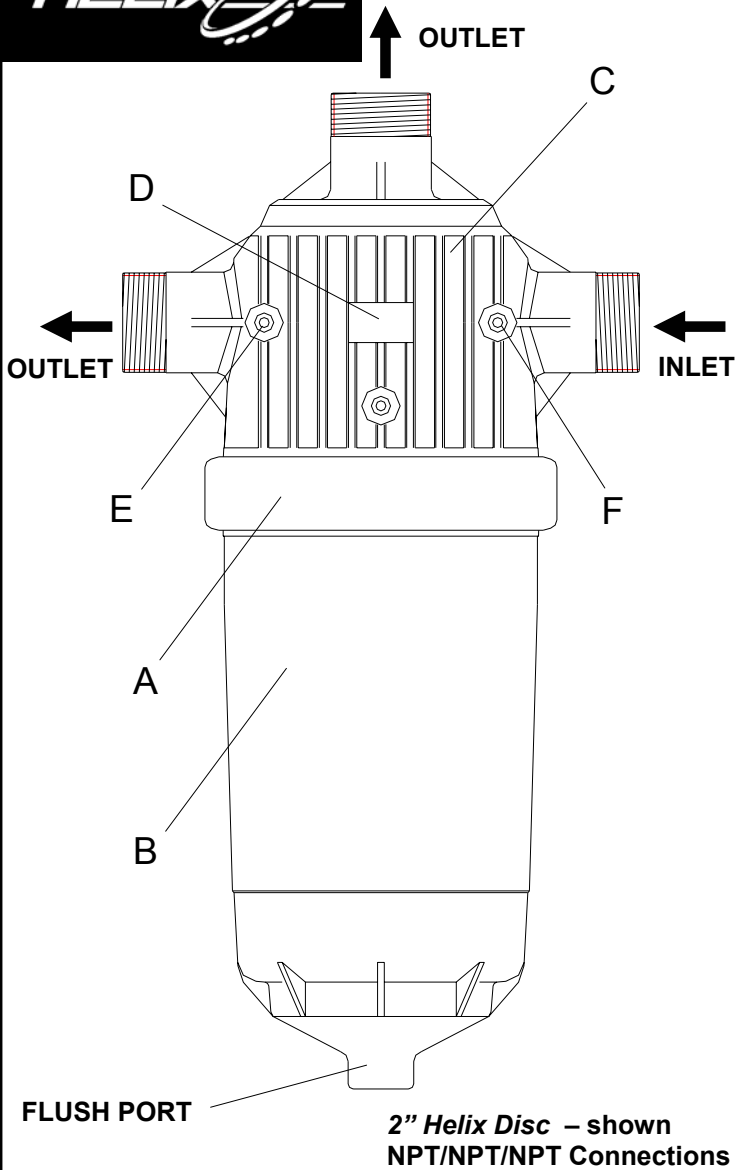

Figure 2

## HELIX FILTER

### Components:

See Diagram to the Left:

- A. Band-Clamp Assembly
- B. Removable Filter Lid
- C. Filter Body
- D. Mesh/Micron Data Plate
- E. Outlet Gauge Port (Clean Water Side)
- F. Inlet Gauge Port (Dirty Water Side)

## HELIX FILTER CARTRIDGES

### Components:

See the Diagram Below:

- G. Screen Cartridge / Disc Cartridge
- H. *Helix* Element
- I. O-Ring Seal
- J. Cartridge Cover Plate
- K. Threaded Wing Bolt (Hand Tighten)

#### MTS Series Screen Cartridge

#### MTD Series Disc Cartridge

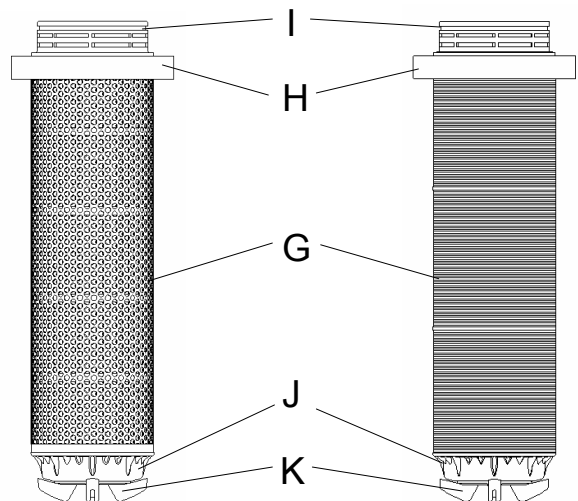

Figure 3

## COMPANY INFORMATION



**MILLER-LEAMAN**  
INCORPORATED

### MILLER-LEAMAN, INC.

800 Orange Avenue, Daytona Beach, FL 32114

Phone: (386) 248-0500 / Fax: (386) 248-3033

[www.millerleaman.com](http://www.millerleaman.com)

email: [sales@millerleaman.com](mailto:sales@millerleaman.com)

Hours: M-F 8:00 AM - 5:00 PM Eastern USA