

ATD-2SV-130 Filter (130 Micron) Polyamide Housing 3 Places

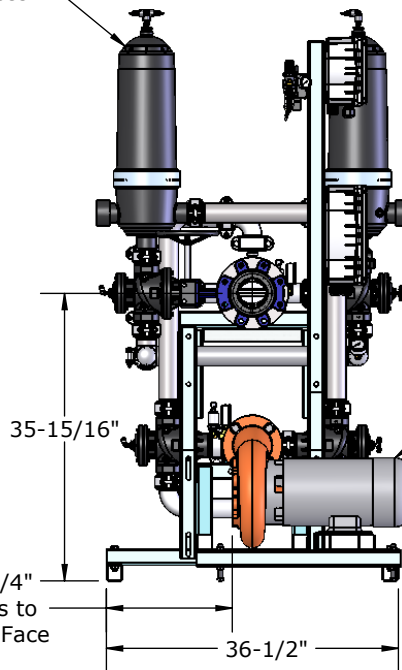

PLC XD-26-Controller & Pneumatic Valve Manifold

Air Connection

System Power Feed & Pump Motor Starter

2 x 2 Angle Flow Valve Polyamide Housing 6 Places

Pressure Transducers & Gauges Inlet / Outlet Manifolds

Booster Pump 2 HP

System Drain Hose Bibb Connection

Backflush Manifold 2" NPT (m)

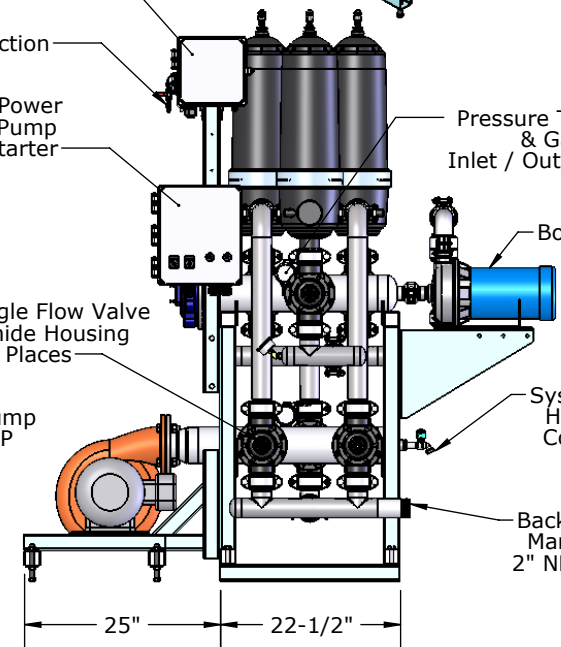

**PRODUCT SPECIFICATION**

**MILLER LEAMAN INC**

800 Orange Ave. Daytona Beach FL 32114

|                            |           |              |
|----------------------------|-----------|--------------|
| DRAWN                      | L.Brannan | 11/4/11      |
| CHECKED                    |           |              |
| ENG APPR.                  |           |              |
| MKT APPR.                  |           |              |
| MLI File # ML21136-3D-MOD1 |           | SHEET 1 OF 1 |

**SYSTEM REQUIREMENTS:**

Electrical: 460VAC/3 Phase/60Hz/15A  
 Air Supply: 2 CFM @ 80 - 100 PSI  
 Water Supply @ Inlet: 10 - 25 PSI  
 System Design: 300 GPM  
 Dry Weight: 825 lbs

TITLE:

**Automatic Turbo Disc Filter Skid System**  
 B1-ATD2(3)x4-130M-P300-A-MOD1\_P