

GENERAL SPECIFICATIONS	
DESIGN FLOW (GPM)	350
MAX PRESSURE (PSI)	150
FILTRATION AREA (SQ IN)	367
DRY WEIGHT (LBS)	68
VOLUME (US GAL)	11
MAX TEMP (°F)	135

MATERIALS	
HOUSING / SCREEN FRAME	304SS
SCREEN	316SS
GASKETS	EPDM
ELBOW & RISER PIPE	PVC
CONICAL FILTER ELEMENT	
PERFORATED SCREEN	TBD
MESH SCREEN	TBD
SCREEN HEIGHT (IN)	15.91
NOTES	
CLEARANCE ABOVE STRAINER EQUAL TO SCREEN HEIGHT REQUIRED FOR SERVICE	

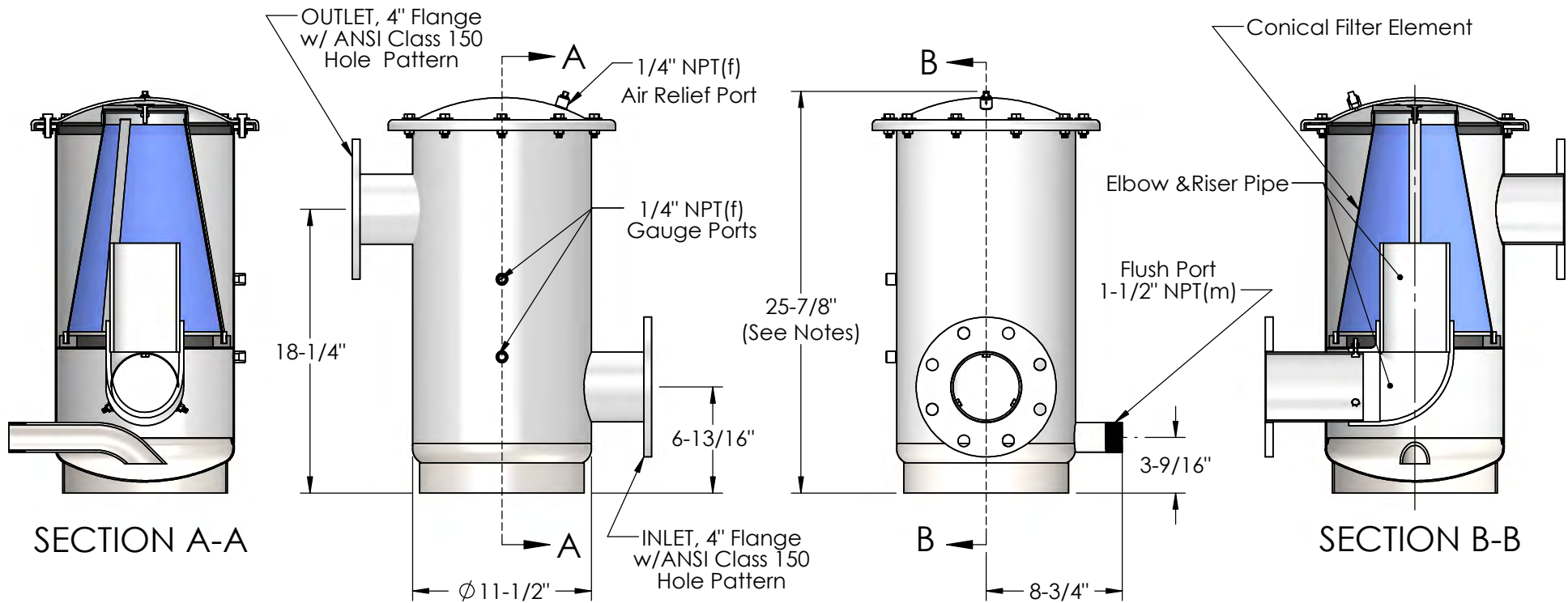

PRODUCT SPECIFICATION

MILLER LEAMAN
800 Orange Avenue, Daytona Beach, FL 32114

Dimensions are for reference only.

CUST. REF.	
PREV. MOD.	MLS-4B
ENG. REF.	ML20252
DWG. DATE	1/28/22

SERIES:	THOMPSON	MODEL:	STRAINER
MODEL NUMBER:		MLS-04B	
CONFIGURATION:		MLS-04B-FP2-304E	

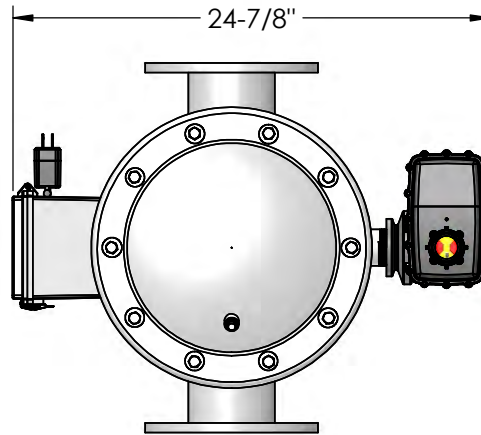
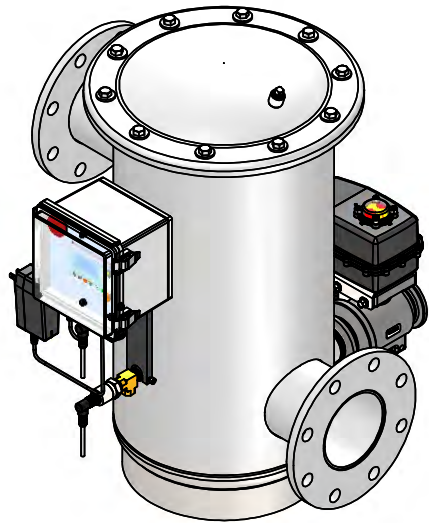

PDA/ATF-MAX

PRESSURE DIFFERENTIAL ALARM (PDA)

- Monitors Differential Pressure
- Signals operator at user-defined set point
- Audible & Visual Alarm
- Auxiliary contact for remote monitoring optional

AUTOMATIC TIMER FLUSH (ATF)

- Purges particles from strainer at user-defined intervals
- Adjustable flush frequency & duration
- Manual override

ELECTRICAL REQUIREMENT (PDA/ATF-MAX)

- 120VAC, 50/60Hz, 1.5Amps
- Power supply fits U.S. Type A or Type B outlet

Pressure Differential Alarm/
Automatic Timer Flush
Control Package
(PDA/ATF-MAX)

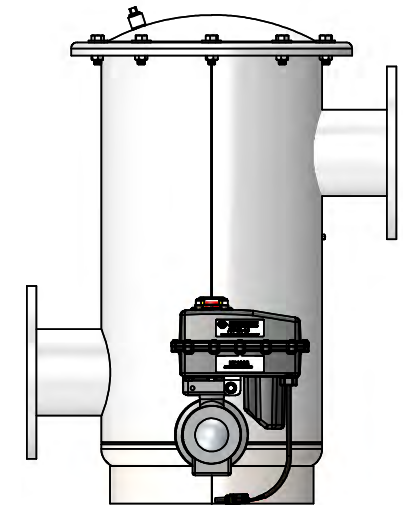
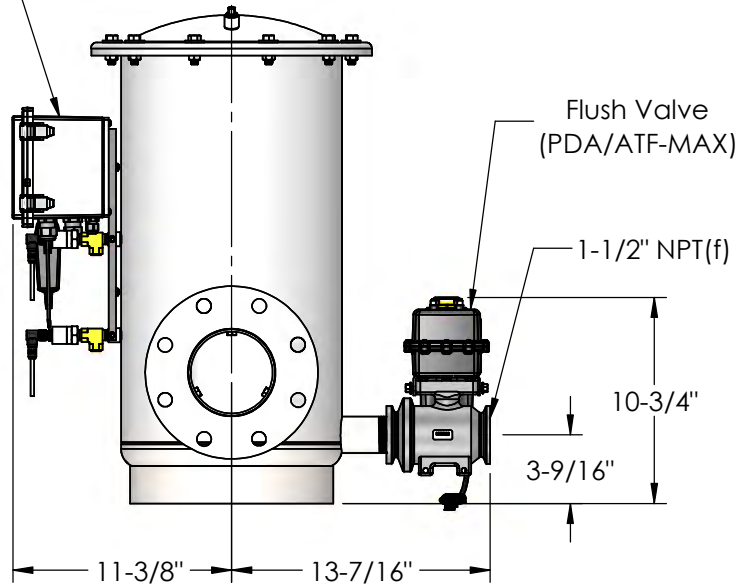
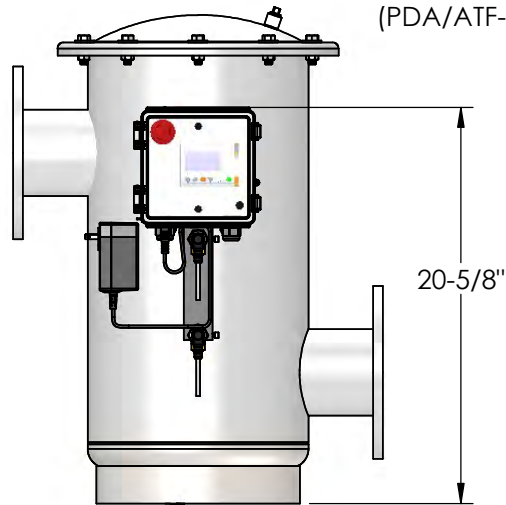

PRODUCT SPECIFICATION

MILLER LEAMAN
800 Orange Avenue, Daytona Beach, FL 32114

Dimensions are for reference only.

CUST. REF.	
PREV. MOD.	
ENG. REF.	ML20252-PDA-ATF-MAX
DWG. DATE	1/28/22

SERIES:
THOMPSON

MODEL:
STRAINER

CONFIGURATION:

Instrumentation Package Options

Thompson Strainer - 4" Exploded View

Complete Strainer
 MLS-04B-**XXX**

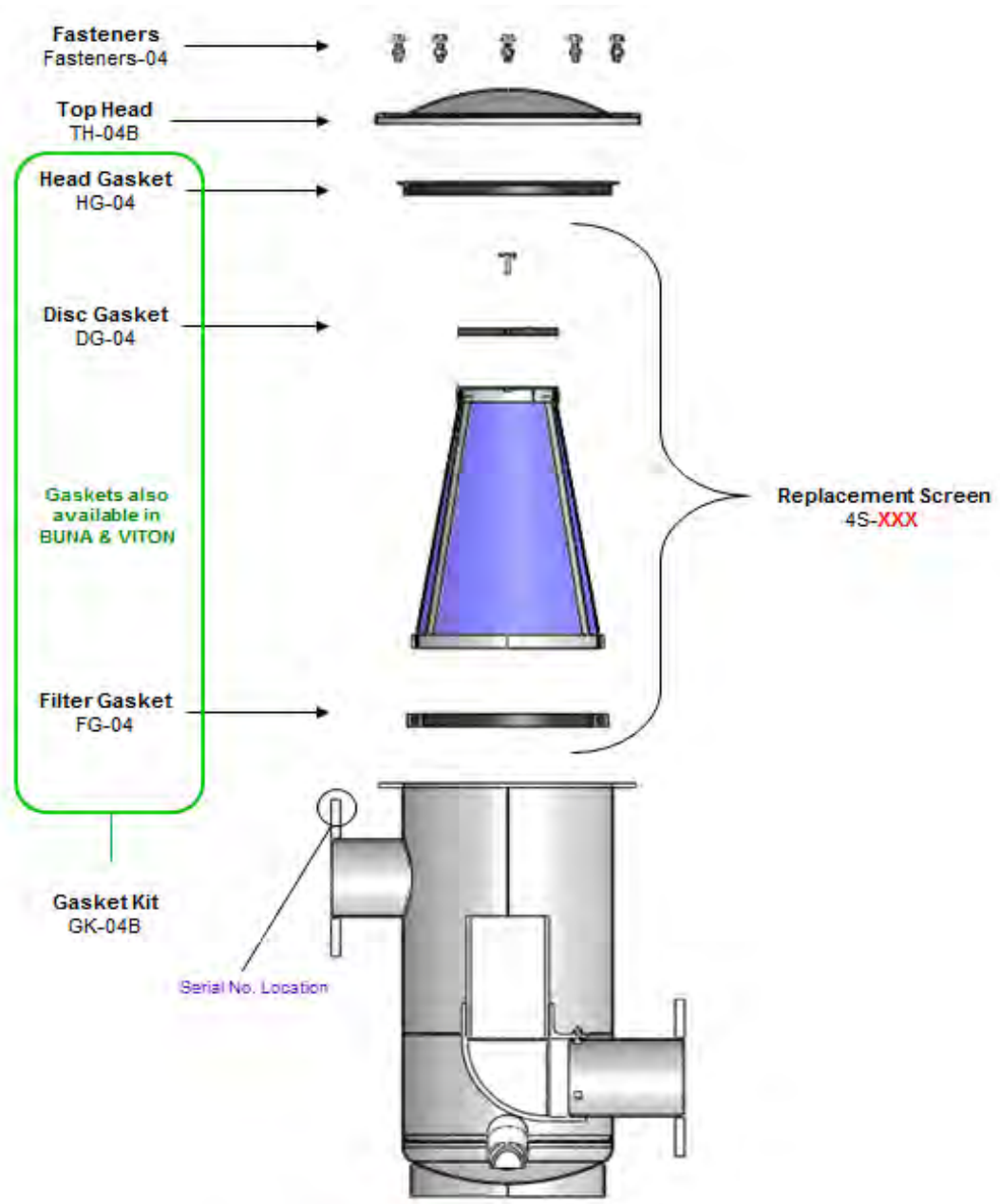

XXX Denotes Mesh Options

Mesh Options – 16, 20, 30, 40, 50, 60, 80, 100, 120, 150, 200
 Heavy Duty Mesh – 24x110, 30x150, 40x200, 50x250 (Dutch weave screens; heavier wire gauge, lower open area %)

MESH / MICRON DATA SHEET

STANDARD MESH OPTIONS

Mesh	Opening (inches)	Microns	Wire Diameter (inches)	Open Area
16	0.0395	1003	0.023	39.90%
20	0.0340	864	0.016	46.20%
30	0.0203	516	0.013	37.10%
40	0.0150	381	0.01	36.00%
50	0.0110	279	0.009	30.30%
60	0.0092	234	0.0075	30.50%
80	0.0070	178	0.0055	31.40%
100	0.0055	140	0.0045	30.30%
120*	0.0046	117	0.0037	30.70%
150*	0.0041	104	0.0026	37.40%
200*	0.0029	74	0.0021	33.60%

HEAVY-DUTY MESH OPTIONS

24 x 110 (≈120 Mesh)	0.0045	112 - 117	.014 / .010	N/A
30 x 150 (≈150 Mesh)	0.0039	95 - 100	.009 / .007	N/A
40 x 200 (≈200 Mesh)	0.0030	72 - 77	.007 / .0055	N/A
50 x 250	0.0024	55 - 60	.0055 / .0045	N/A

*Miller-Leaman recommends the purchase of the heavy-duty mesh options as alternatives to the finer, more fragile standard screen options (120, 150, and 200 mesh). Be advised, however, that the heavy-duty mesh options have less open area percentage and will require more frequent maintenance in some applications.

Standard screens are comprised of 1/4" perforated backup material with selected screen mesh. Optional perforated only (no mesh) screens are available in 1/4", 1/8" 1/16" and 5/64". Other sizes or sintered mesh available by special order.

Mesh/Micron Conversion Formula
 Microns = opening in inches / .00003937



"THOMPSON" STRAINER

EFFICIENCY CURVES

INDUSTRY'S LOWEST PRESSURE DROP

All Thompson Strainers have been designed to operate with less than a 1 PSI pressure loss during flow rate when clean. This exceptional efficiency results in less energy consumption and reduced operating costs. Call us today for a free energy savings estimation.

MLS-2 Design Flow Rate: 100 GPM

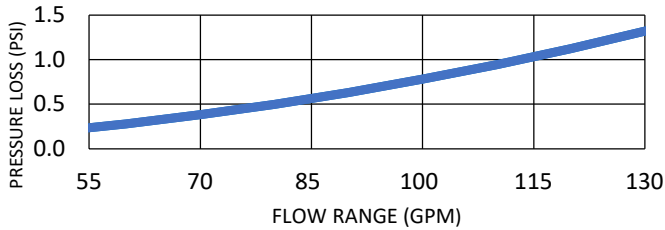

MLS-3 Design Flow Rate: 200 GPM

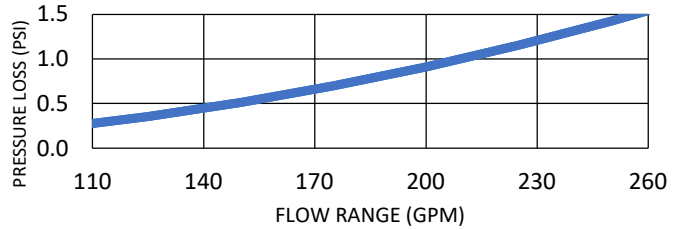

MLS-4 Design Flow Rate: 350 GPM

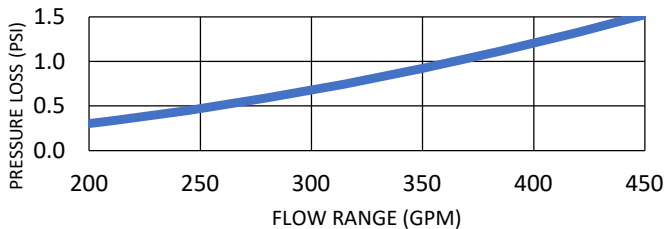

MLS-6 Design Flow Rate: 750 GPM

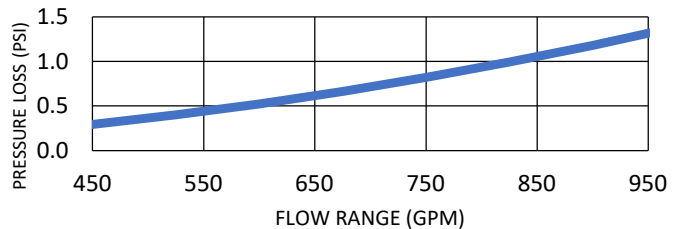

MLS-8 Design Flow Rate: 1300 GPM

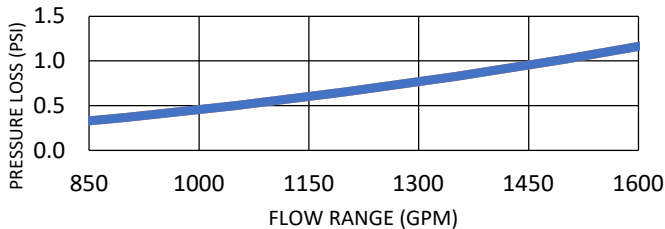

MLS-10 Design Flow Rate: 2000 GPM

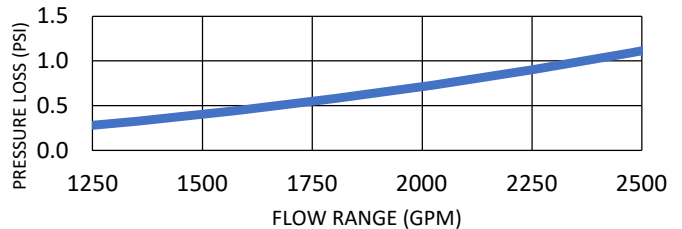

MLS-12 Design Flow Rate: 3000 GPM

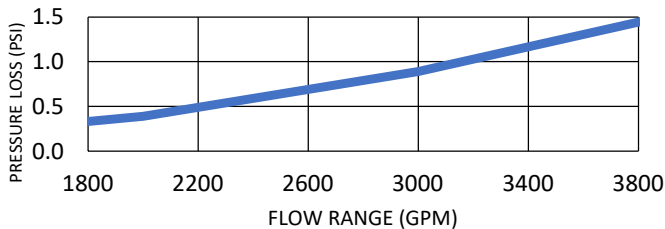

MLS-14 Design Flow Rate: 4000 GPM

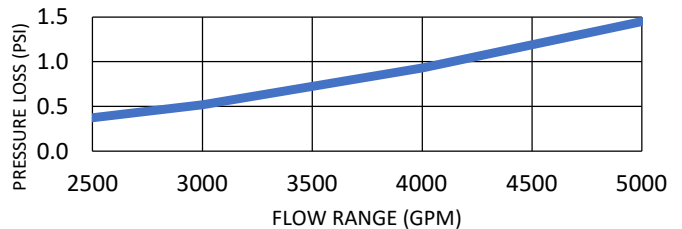

MILLER LEAMAN

800 Orange Ave. · Daytona Beach, FL 32114
 tel: 386.248.0500 · toll free: 800.881.0320
 fax: 386.248.3033 · www.millerleaman.com

THE RIGHT SOLUTION FOR A WIDE RANGE OF SCREEN FILTRATION PROJECTS

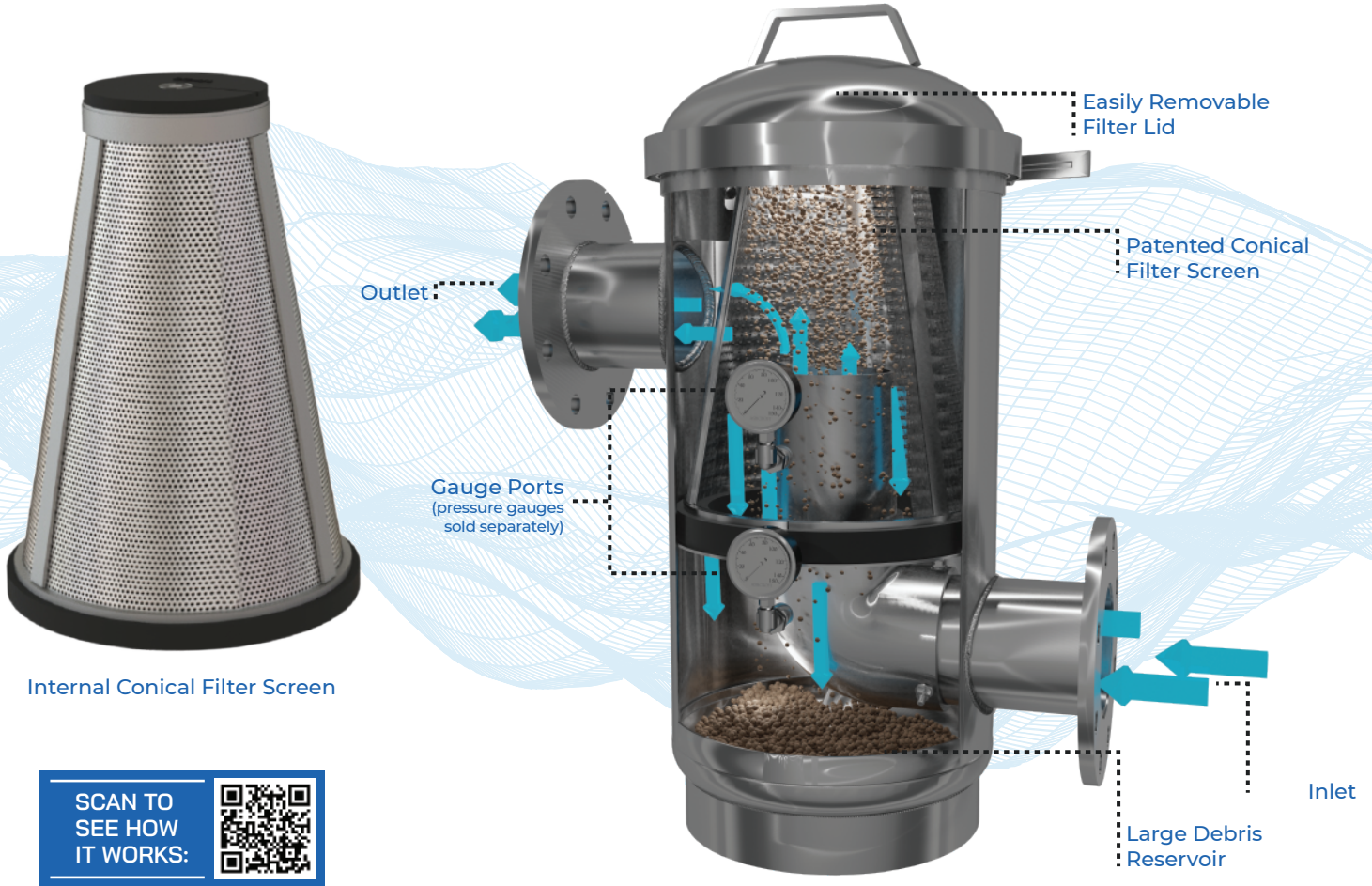

SCAN TO SEE HOW IT WORKS:



APPLICATIONS

- | | | | | | |
|-------------------------------|---------------|------------------------------|---------------------|-----------|-------------------------|
| Cooling Tower / Chilled Water | Process Water | Food / Beverage Applications | Chemical Processing | Hot Water | Pump & Valve Protection |
| Plastics / Extrusion | Agricultural | Wastewater / Reclaim Water | Liquid Fertilizer | Mining | Marine |

HOW IT WORKS

1. Dirty water enters inlet at bottom of housing.
2. Dirty water flows up through riser pipe assembly.
3. "Hydraulic" action and gravity accelerates heavier particles down to bottom debris reservoir.
4. Particles are flushed from strainer reservoir via 1.5" port.
5. Clean water exits through outlet port at top of housing.

BENEFITS

- Large screen surface area
- Minimizes operating costs
- Less than 1 PSI of pressure loss (clean)
- Streamlined design
- Space saving profile
- Completely customizable
- High-quality stainless steel construction

OPTIONAL ADD-ONS

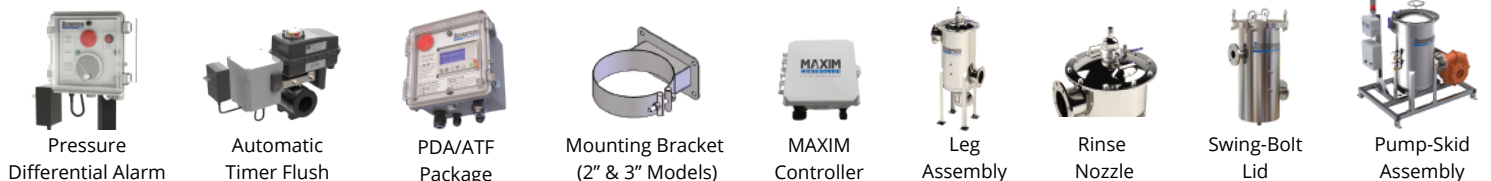

STANDARD MODELS

Model #	Inlet/Outlet Size & Type	Recommended Flow* (GPM)	Max Pressure Rating**	Lid Closure Type	Screen Surface Area (sq. in.)	Dimensions (inches)					Weight (lb)	
						A	B	C	D	E	DRY	WET
MLS-2	2"/NPT or Grooved	100 GPM	125 PSI	CLAMP	122	7.5	17.62	6.18	11.75	--	14	30
MLS-3	3"/NPT or Grooved	200 GPM	125 PSI	CLAMP	200	10	26	8.19	16.82	--	30	60
MLS-4C	4"/Flanged or Grooved	350 GPM	125 PSI	CLAMP	367	12.75	28.75	9.62	18.25	6.81	60	160
MLS-4B	4"/Flanged or Grooved	350 GPM	150 PSI	BOLTED	367	14.5	25.88	9.62	18.25	6.81	60	160
MLS-6	6"/Flanged or Grooved	750 GPM	150 PSI	BOLTED	745	20.52	38	12.25	29.12	10.25	125	425
MLS-8	8"/Flanged or Grooved	1000 GPM	150 PSI	BOLTED	1659	26	49.06	16.89	35.31	11.88	200	995
MLS-10	10"/Flanged or Grooved	2000 GPM**	150 PSI	BOLTED	2432	14.5	60.25	19.88	45.56	13.19	400	1840
MLS-12	12"/Flanged or Grooved	3000 GPM	150 PSI	BOLTED	2432	20.52	60.25	19.88	45.56	12.12	425	1865
MLS-14	14"/Flanged or Grooved	4000 GPM	150 PSI	BOLTED	2432	26	63.75	19.88	47.50	15	553	2013

Each strainer comes with 1/4" NPT gauge and air relief ports and 1.5" NPT threaded flush ports. Pressure gauges and flush valves are not included.

*Recommended flow varies depending on solids loading and screen sizing. Manifold multiple strainers for higher flow rates.

**High pressure and high temperature models available by special order.

CONSTRUCTION MATERIALS

Housing & Internal Piping:

- Type 304 stainless Steel (Type 316 is optional)
- 2"-14" models come standard with internal elbow and riser pipe assembly

Internal Conical Screen Elements

- Screen Support Frames: Type 304 stainless-steel
- Screen Mesh: Type 316 stainless-steel is standard

Gaskets

- EPDM is standard
- VITON and BUNA gaskets available by special order

Lid Fasteners

- Clamp Lid Models: 2"-4" *Clamp is type 304 SS*
- Optional: 316 SS
- Bolted Lid Models: 4"-14" *Grade 5 bolts/nuts; Zinc plated washers*
- Swing-Bolt lid optional

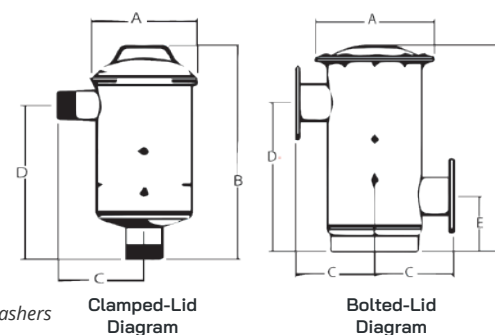

SCREEN SIZES AVAILABLE

MESH / micron data	Mesh size	16	20	30	40	50	60	80	100	120*	150*	200*
	Microns	1003	864	516	381	279	234	178	140	117	104	74

*Heavy-duty mesh recommended

HEAVY-DUTY MESH / micron data

Mesh size	24x110	30x150	40x200	50x250
Microns	112-117	95-100	72-77	55-60
Perforated Screen Sizes (in.)	1/4	1/8	1/16	5/64



Custom filtration options



Conserving water and energy for sustainability



Rigorously tested welds



Efficient, clean designs



Agile customer service technicians

EFFICIENT & RELIABLE FILTRATION SOLUTIONS

With over 30 years of experience in manufacturing filtration products for our customers, Miller-Leaman, Inc. has proven credibility, expertise and quality with every system we design. We take pride in our craftsmanship and innovation while providing customizable solutions for our customers across multiple end markets.



Scan the QR code to find out more information about our products.

[f /MillerLeaman800](#)
[i /MillerLeaman](#)
[t /Miller-Leaman](#)



MILLER-LEAMAN

800 Orange Ave, Daytona Beach, FL 32114
 Phone: 386.248.0500 | Fax: 386.248.3033
www.millerleaman.com

THOMPSON INSTRUMENTATION PACKAGES

****NEW STATE-OF-THE-ART-DESIGNS!****

For enhanced capability, any Thompson Strainer can be outfitted with a Pressure Differential Alarm, Automatic Timer Flush Package or both.



APPLICATIONS

- Cooling Tower / Chilled Water
- Food / Beverage Applications
- Hot Water
- Plastics
- Wastewater / Reclaim Water
- Mining
- Process Water
- Chemical Processing
- Pump & Valve Protection
- Agricultural
- Liquid Fertilizer
- Marine

THOMPSON PDA/ATF-MAX POWERED BY MAXIM

PDA/ATF-MAX-150 - POWERED BY MAXIM

The PDA/ATF-MAX combines the Automatic Timer Flush Package with Miller-Leaman's proprietary MAXIM controller PLC and pressure transducers to monitor the differential pressure across the internal screen. The MAXIM controller allows the user to adjust the PSID alarm set point which will trigger the audible siren and flashing red light alarms as well as actuate the Automatic Timer Flush Package.



PDA MAX - POWERED BY MAXIM

- 110V/24VDC Power Supply
- PLC Controller featuring –
 - LCD Screen for System Status Info, Setpoint Adjustability, and System Alarm Info.
 - Inlet/Outlet Pressure Transducers
 - Memory Module Interface for Program Backup.
 - I/O System Screen for Troubleshooting Assistance.
- Pressure Transducers for Increased Accuracy of Differential Pressure Calculation and System Pressures.
- Alarm Output Relay for Your Building Management System.
- Nema4X Enclosure Rating with Clear Enclosure Cover for Status and Alarm Viewing.

AUTOMATIC TIMER FLUSH (ATF2)

- Automatically Purges Particles from Bottom Reservoir
- Increased ATF function-ability – “TimedFlush” enabled only when System Flow is Detected.
- Manual Flush Override
- NEMA 4X Enclosure Rating
- 316 SS Ball and Stem
- Less Connections and Reduced Leak Point
- Open and Close Indicator
- Valve Threads On Strainer Flush Port (Standard 1.5”)
- Other Flush Sizes Available (0.75”, 1”, 2”, 3”).
- Adjustable Flush Frequency and Flush Duration controlled by MAXIM

Flush Interval
HOURS:MM 00024:00
Enter
PSID Setpoint 07

Manifold Pressure
Inlet : 0034.0
Outlet : 0032.0
PSID : 0002.0

Time Since Last
Flush 00000:04
Triggered By:
PD Transducers

Example of Multiple Controller Displays





We take pride in conserving water and energy for the sustainability of our environment

THOMPSON

PDA2

A MILLER-LEAMAN PRODUCT



PRESSURE DIFFERENTIAL ALARM PACKAGE (PDA2)

Our new and improved Pressure Differential Alarm Package (PDA2) continuously monitors the pressure drop across the internal conical screen. When the strainer screen becomes dirty, the switch-gauge triggers an audible and visual flashing alarm, intended to alert maintenance personnel when the screen needs to be removed from the housing for manual cleaning. The alarm is factory set to engage when the differential pressure reaches approximately 7 PSID; however, this setting is adjustable by changing the set point contact at the base of the differential pressure gauge.

- 110V / 12VDC Power Supply
- Monitors Differential Pressure
- Signals When Screen Cleaning is Required
- Audible and Visual Alarm
- Auxiliary Contacts For BMS Monitoring
- Nema4X Enclosure Rating

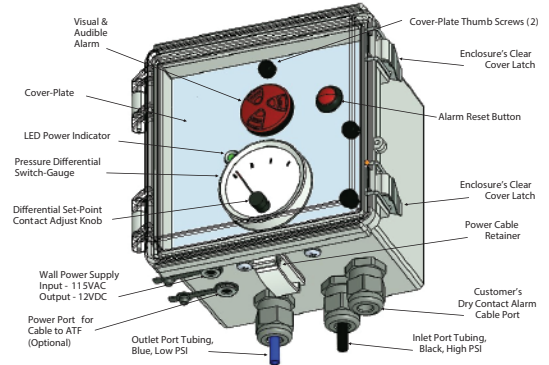

THOMPSON

ATF2

A MILLER-LEAMAN PRODUCT

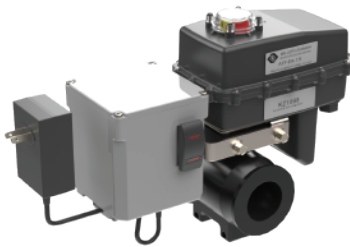

AUTOMATIC TIMER FLUSH PACKAGE (ATF2-150)

The Automatic Timer Flush Package (ATF2-150) automatically purges particles that have gravitated down into the debris reservoir at the base of the strainer. Depending on the solids' loading of the application, the user simply dials in the FLUSH FREQUENCY (time between flushes) and FLUSH DURATION (length of flush) of the valve. The flush frequency is preset for (24) hours and the flush duration is preset for (8) seconds, however, these settings can be changed. Based on the parameters programmed, the robust stainless steel ball valve opens and closes. The user can override the timer by engaging a manual flush cycle.

- 110V / 12VDC Power Supply
- Automatically Purges Particles from Bottom Reservoir
- Robust Stainless Steel Ball Valve
- Adjustable Flush Frequency and Flush Duration
- Manual Flush Override
- Nema4X Enclosure Rating
- Valve Threads On Strainer Flush Port (Standard 1.5")
- Other flush sizes available (0.75", 1", 2", 3")

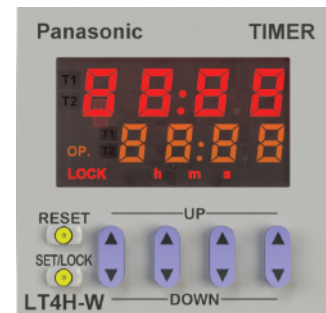

Digital Control Gauge

EFFICIENT & RELIABLE FILTRATION SOLUTIONS



Custom filtration options



Conserving water and energy for sustainability



Rigorously tested welds



Efficient, clean designs



Agile customer service technicians

With over 30 years of experience in manufacturing filtration products for our customers, Miller-Leaman, Inc. has proven credibility, expertise and quality with every system we design. We take pride in our craftsmanship and innovation while providing customizable solutions for our customers across multiple end markets.



800 Orange Ave, Daytona Beach, FL 32114
Phone: 386.248.0500 | Fax: 386.248.3033
www.millerleaman.com



Scan the QR code to find out more information about our products.

f /MillerLeaman800
t /MillerLeaman
o /Miller-Leaman

