

REVISIONS			
REV	DESCRIPTION	DATE	APPROVAL
cler cng	Corrected 4&6 Pin Connector plug part dash numbers.	2/19/2015	DMP

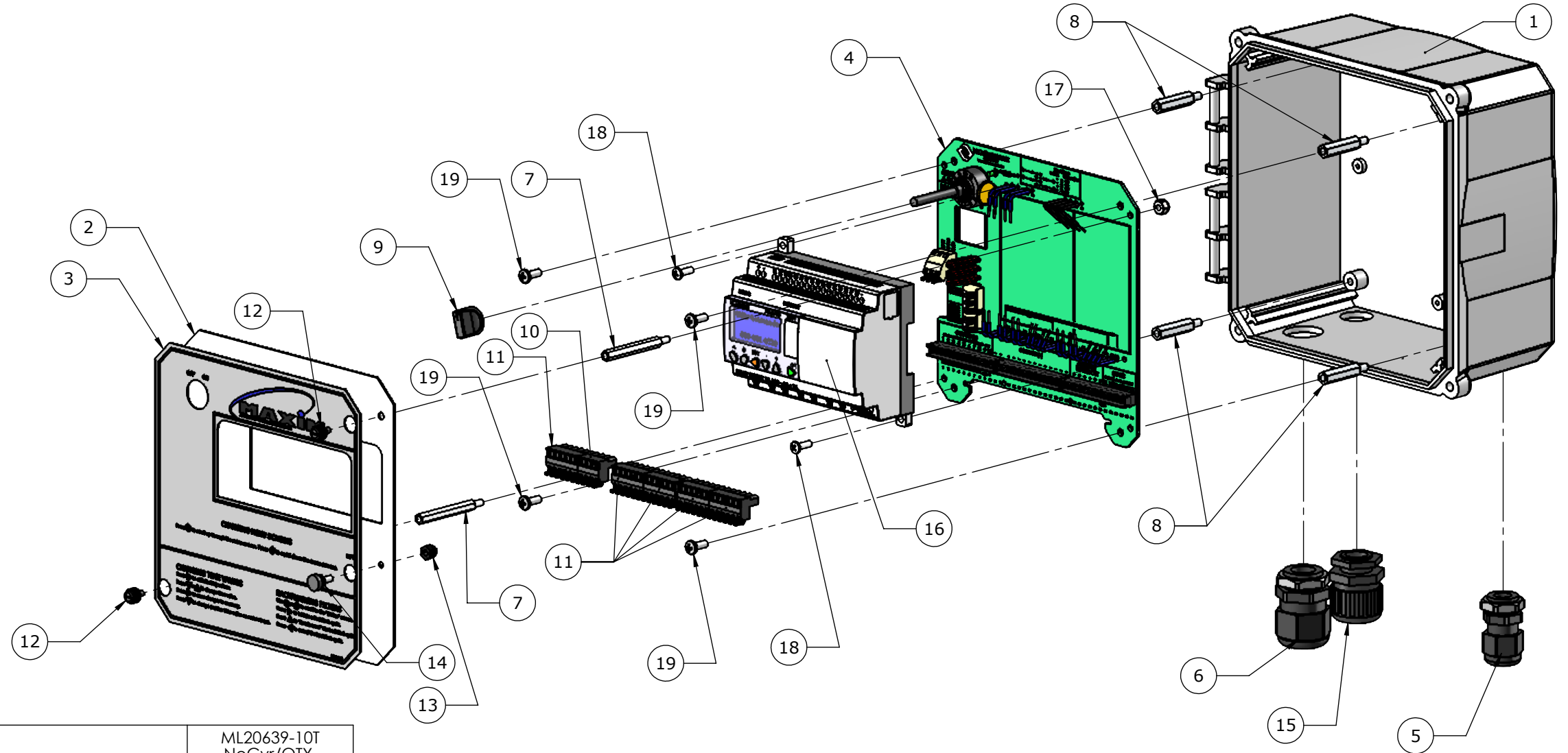
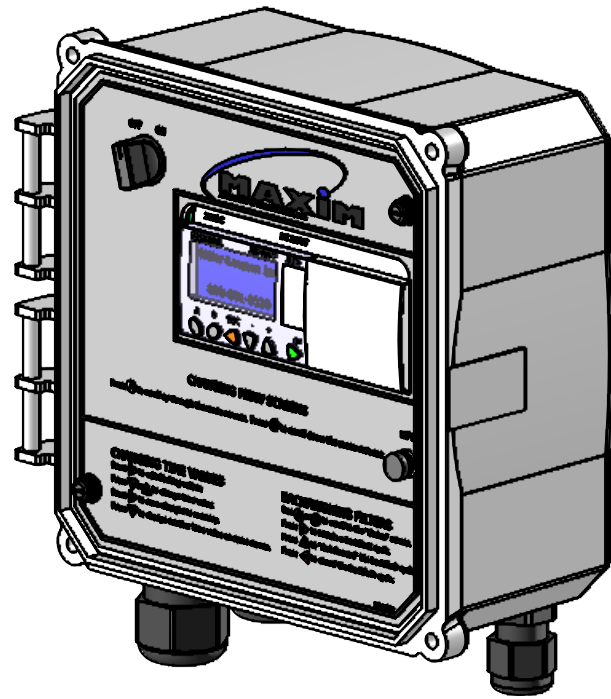

ITEM NO.	PART NUMBER	DESCRIPTION	ML20639-10T NoCvr/QTY.
1	ML10203-02	Enclosure, Maxim Control Box Modified	1
2	ML10504-2	Face Plate, for M8 & M10, Millenium 3	1
3	ML10545-1	Label Face Plate, M8, M10	1
4	ML20640-10	M10 Controller Wire Configuration	1
5	PS00046-03	Strain Relief, 1/2" NPT	1
6	PS00046-04	Strain Relief, 3/4" NPT	1
7	PS00253-2	Standoff 2" long, Alum (1/4" hex #8 thread)	2
8	PS00477-1	Standoff, 1.25" - Alum., 5/16" hex #10 thread	4
9	PS00481	Knob, Black Plastic, 1/4" Shaft	1
10	PS00483-4	Connector Plug, Spring Latch, 5 mm 4 pin	1
11	PS00483-6	Connector Plug, Spring Latch, 5mm 6 Pin	5
12	PS00497	Thumb Screw, Nylon Black 8-32 x 3/16" Slot-Head	2
13	PS00517	Cap Nut, Acorn, Nylon-Black, 8-32	1
14	PS00518	Thumb Screw, Nylon Black-8-32 x 3/8"	1
15	PS00639-03	Strain Relief, Conduit, 1/2NPT x 1/2 Cond, DOF N-FGW21-21-B	1
16	PS01580-2	PLC -Crouzet XD26 - 24VDC	1
17	PS90252-16	Nut, #8-32 Nyloc Hex, Stainless Steel	2
18	PS90739-0008	Screw, 8-32 x 1/2 stainless phillips pan head screw	2
19	PS90751-0008	Screw, Pan head 10-32 CR-PHMS - 1/2" Long	4

NOTES:
1- PART TO BE FREE OF BURRS AND SHARP EDGES.

SEE SHEET 2 OF 2 FOR ELECTRICAL SCHEMATIC.

PROPRIETARY AND CONFIDENTIAL
THE INFORMATION CONTAINED IN THIS DRAWING IS THE SOLE PROPERTY OF MILLER - LEAMAN INC. ANY REPRODUCTION IN PART OR AS A WHOLE WITHOUT THE WRITTEN PERMISSION OF MILLER-LEAMAN INC. IS PROHIBITED.

UNLESS OTHERWISE SPECIFIED: -DIMENSIONS ARE IN INCHES -DIMENSIONING & TOLERANCING PER ASME Y14.5 -TOLERANCES: FRACTIONAL: +1/32 ANGULAR: ±1/4° TWO PLACE DECIMAL ±.02 THREE PLACE DECIMAL ±.005	DRAWN	NAME	DATE
MATERIAL	RELEASED	DMP	10/17/2014
FINISH	ECN CTRL		
DO NOT SCALE DRAWING	MFG APPR		
	Q.A.		
	COMMENTS:		

DRAWN		NAME		DATE		 800 Orange Avenue, Daytona Beach, FL 32114	
RELEASED		DMP		10/17/2014			
ECN CTRL						TITLE:	
MFG APPR						Maxim 10, XD26-24VDC, w/o PD gauge, w/o Power Supply	
Q.A.						SIZE DWG. NO.	
						B ML20639-10T	
						REV	
						--	
SCALE:1:12		WEIGHT:				SHEET 1 OF 2	

Starter Box Connections

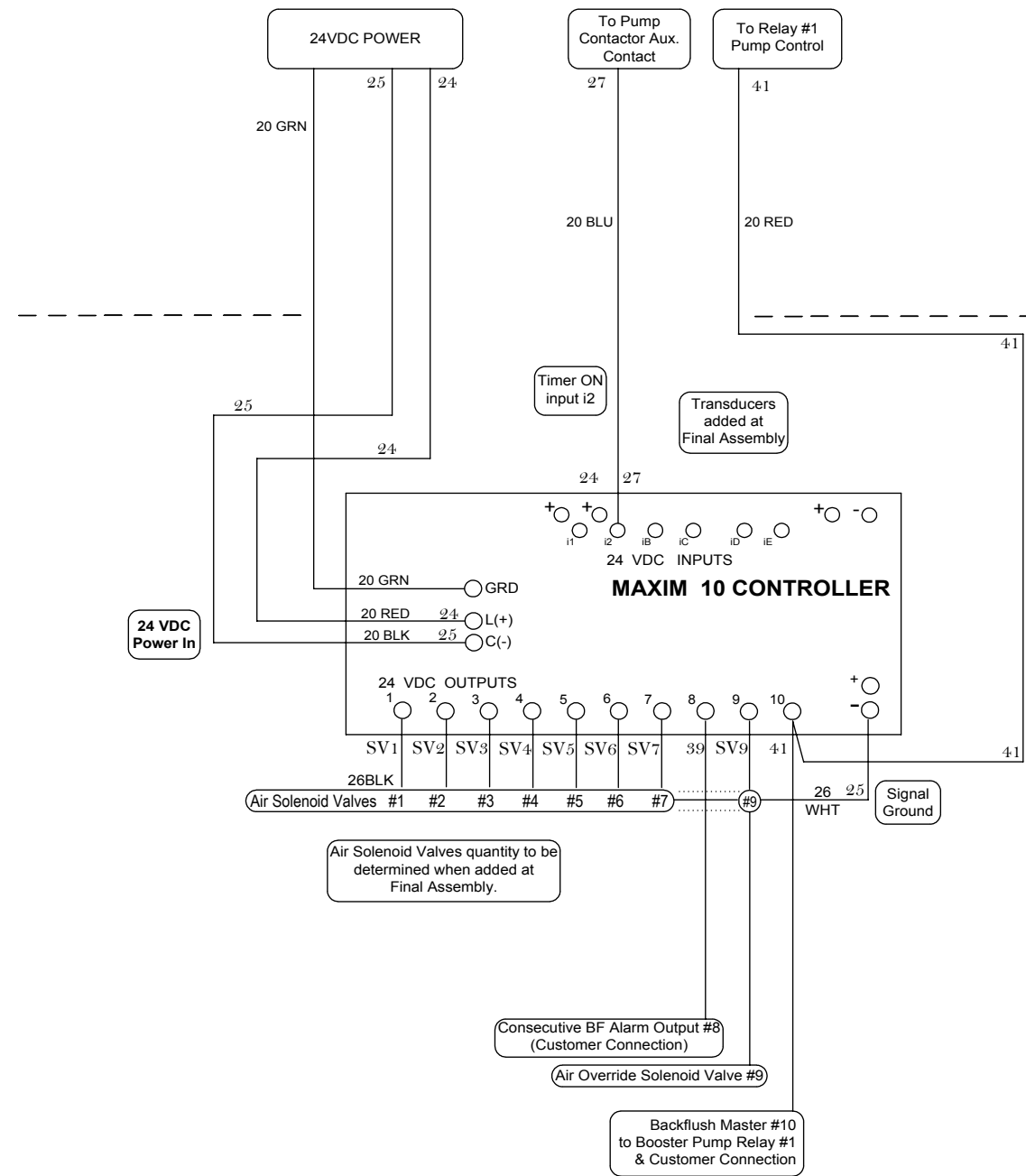

PROPRIETARY AND CONFIDENTIAL
 THE INFORMATION CONTAINED IN THIS DRAWING IS THE SOLE PROPERTY OF MILLER-LEAMAN INC.
 ANY REPRODUCTION IN PART OR AS A WHOLE WITHOUT THE WRITTEN PERMISSION OF MILLER-LEAMAN INC. IS PROHIBITED.

UNLESS OTHERWISE SPECIFIED: - DIMENSIONS ARE IN INCHES - DIMENSIONS & TOLERANCES PER ASME Y15.5 STANDARDS - TOLERANCES: FRACTIONAL +/- 1/32 ANGULAR +/- 1/4 deg TWO PLACE DECIMAL +/- .02 THREE PLACE DECIMAL +/- .005		NAME	DATE
DRAWN	DMP	10/17/2014	
CHECKED			
ENG APPR			
MFG APPR			
MATERIAL		COMMENTS:	
FINISH			
DO NOT SCALE DRAWING			

MILLER - LEAMAN ^{INC}	
800 Orange Avenue, Daytona Beach, FL 32114	
TITLE: Electrical Schematic Maxim 10 Controller, XD26, 24VDC, No DP Gauge, No Power Supply	
SIZE B	DWG. NO. ML20639-10T
SCALE: 1:1	WEIGHT:
SHEET 2 OF 2	