

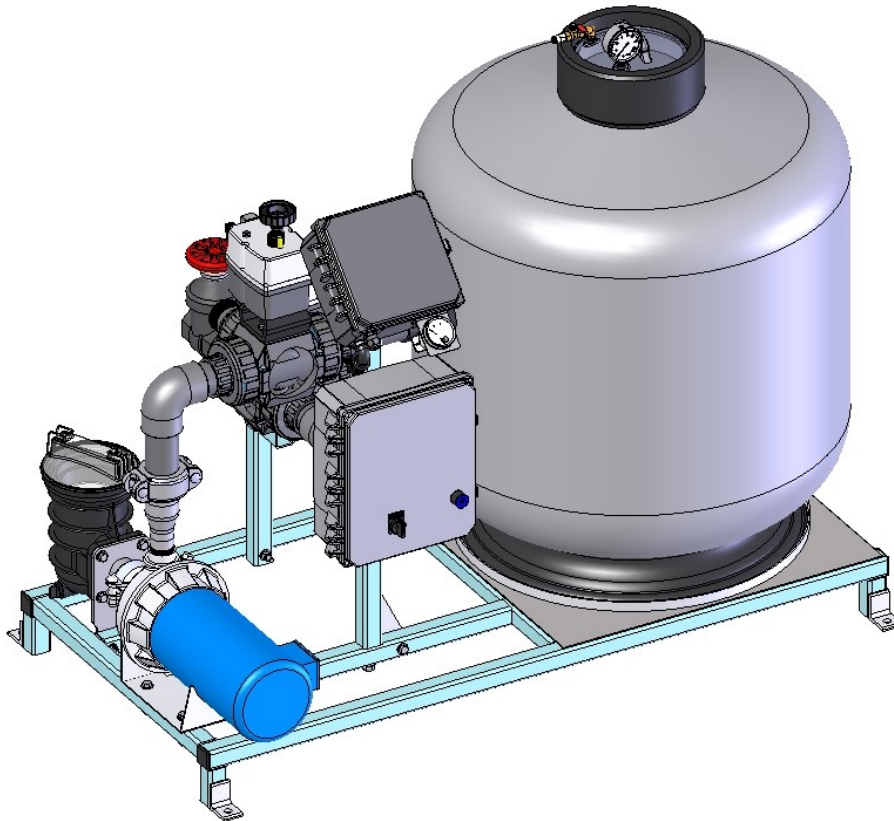

*OWNER'S MANUAL*  
*Operation and Maintenance Guide*  
*TGSS-20C, TGSS-24C, and TGSS-30C*



**MILLER**  **LEAMAN** <sup>INC</sup>

800 Orange Ave. · Daytona Beach, FL 32114  
tel: 386.248.0500 · toll free: 800.881.0320  
fax: 386.248.3033 · [www.millerleaman.com](http://www.millerleaman.com)

**Miller-Leaman, Inc.**

- 800 Orange Avenue • Daytona Beach, FL 32114 •
- Toll Free: 800 881-0320 • Phone: 386 248-0500 • Fax: 386 248-3033 •
- E-mail: [sales@millerleaman.com](mailto:sales@millerleaman.com) • Web Site: [www.millerleaman.com](http://www.millerleaman.com) •

**First Edition**

**Copyright © 2017 by Miller-Leaman, Inc.** - 800 Orange Avenue, Daytona Beach, FL 32114  
Printed in the United States of America. All rights reserved. This manual or parts thereof may not be reproduced in any form, mechanical, electronic, Internet, or in any form without the written permission of Miller-Leaman, Inc.

Toll Free: 800 881-0320 • Phone: 386 248-0500 • Fax: 386 248-3033  
E-mail: [sales@millerleaman.com](mailto:sales@millerleaman.com) • Web Site: [www.millerleaman.com](http://www.millerleaman.com)

# Introduction

Thank you for purchasing Miller-Leaman's *TowerGuard* Filter System. With proper installation, operation, and maintenance, the *TowerGuard* will provide trouble-free automatic filtration. This manual will provide the details required to understand the function, design, operation, and maintenance of your filter. Please read this manual completely before installing and operating the *TowerGuard* System. IT IS IMPORTANT THAT PERSONS WHO ARE TO OPERATE AND MAINTAIN THIS SYSTEM FULLY UNDERSTAND THESE INSTRUCTIONS PRIOR TO OPERATION.

Please review the *MAXIM* Owner's Manual section as well before operating the system. The *MAXIM* manual will explain the system settings and how to adjust values such as the backflush frequency and duration.

Should there be any questions concerning the system, please contact our application specialists at 386-248-0500, or e-mail us at [sales@millerleaman.com](mailto:sales@millerleaman.com).

## *TowerGuard* Sand Filter City Water Backflush Model

- TGSS-20C 1P - 20" *TowerGuard*  
with 1-Phase Pump
- TGSS-20C 3P - 20" *TowerGuard*  
with 3-Phase Pump
- TGSS-24C 1P - 24" *TowerGuard*  
with 1-Phase Pump
- TGSS-24C 3P - 24" *TowerGuard*  
with 3-Phase Pump
- TGSS-30C 1P - 30" *TowerGuard*  
with 1-Phase Pump
- TGSS-30C 3P - 30" *TowerGuard*  
with 3-Phase Pump

Each *TowerGuard* system is identified with a Serial Number to ID the system's components and records. The Serial Number is located on the data plate label. This label is typically placed on the *MAXIM* Controller coverplate outside with a duplicate copy on the inside cover.

### **TOWERGUARD SERIAL NUMBER:**

**TG** - \_\_\_\_\_

The *MAXIM* Controller also contains a serial number to ID the software and controller type. This Serial Number is located on the left side of the controller box.

### **MAXIM SERIAL NUMBER:**

**M8** - \_\_\_\_\_

# Safety

## Safety Considerations

Safety precautions are essential when any filtration equipment is involved. These precautions are necessary when using, storing, and servicing your filter. If safety precautions are overlooked or ignored, personal injury or product damage may occur. Your filter was designed for specific applications. It **should not** be modified and/or used for any application other than originally specified. If there are any questions regarding its application or installation, contact Miller-Leaman, Inc.

### **ALWAYS OBSERVE THE FOLLOWING PRECAUTIONS:**

- 1) Read this manual carefully. Consider the applications, limitations, and the potential hazards specific to your filter.
- 2) **Absolutely, under no conditions, should the filter vessel cover, pressure gauges, or valves be removed while the filter is pressurized.**
- 3) Units with damaged or missing parts should **never** be operated. Contact our customer service representatives for replacement parts.
- 4) This filter system is not freeze protected. If the liquid filled components freeze, system damage may occur. If there is a risk of freezing, install the system indoors or freeze protect its components with heater tape and insulation.
- 5) Do not connect the pump inlet to a pressurized line as these systems are designed for side-stream applications only.

**NOTE - At no time should the internal vessel pressure exceed the maximum rated pressure of 50 PSI.**

## Table of Contents

1) Introduction .....	3
2) Safety .....	4
3) Introduction to <i>TowerGuard</i> Automatic Filtration .....	5
4) <i>TowerGuard</i> - City Water Backflush Model - Description .....	6
5) <i>TowerGuard</i> Installation Guidelines and Procedures .....	7
6) System Startup and Shutdown .....	9
7) Filter Maintenance .....	11
8) <i>TowerGuard</i> - City Model Spare Parts List .....	11
9) <i>TowerGuard</i> Side Mount Sand Filter Parts List .....	12
10) <i>MAXIM</i> Backflush Controller Introduction & Installation .....	13
11) Differential Pressure Gauge Connections & Set Point .....	13
12) Electrical Detail (Power, Outputs, & Inputs) .....	14
13) Viewing the Menu Status Screens & Adjusting Values .....	15
14) Initial Power Up Screen Sequence .....	15
15) Monitoring the System Status & Controller Feedback Screens .....	18
16) Warranty .....	20

# Introduction to TowerGuard Automatic Filtration

**Sand Media Filtration** — The Miller Leaman *TowerGuard* Filter series utilizes sand media as a means to filter cooling tower water. The *TowerGuard* will remove suspended solids as low as 10 microns with standard sand media. The system is designed for side-stream applications only.

**TowerGuard Design** - The design of the *TowerGuard* allows for simple automatic water filtration. The *TowerGuard* starts with a durable welded stainless steel frame to support its components. A fiberglass reinforced vessel is connected to a TEFC pump via Schedule 80 PVC. The *MAXIM* Controller switches two electrically actuated 3-way valves in order to divert flow for the backflush cycle.

The major system components are identified and described in the table below. Please reference the Product Specification for your system's specific component identification, as the *TowerGuard* systems come in multiple sizes depending upon the desired flow rate.

## System Components

### **Frame / Skid**

The T304 stainless steel welded frame supports the system components while providing high durability and strength.

### **Filter Housing**

The fiberglass reinforced polyester filter housing which contains the sand media bed. This housing is sized for the system's flow rate.

### **Pump**

The TEFC pump is matched to the flow rate of the filter and provides the necessary flow of water through the sand media filter.

### **MAXIM Backflush Controller**

The *MAXIM* backflush controller monitors the system's pressure differential and controls the backflush cycle. It can actuate a backflush cycle by pressure differential (PD), elapsed time, or manually by a user selection. All of the backflush parameters are user adjustable via the *MAXIM*'s user-friendly menus.

### **System Piping**

The inlet and outlet manifolds direct the flow of water to and from the filter housing. The piping is constructed of Schedule 80 PVC.

# TowerGuard - City Water Backflush Model

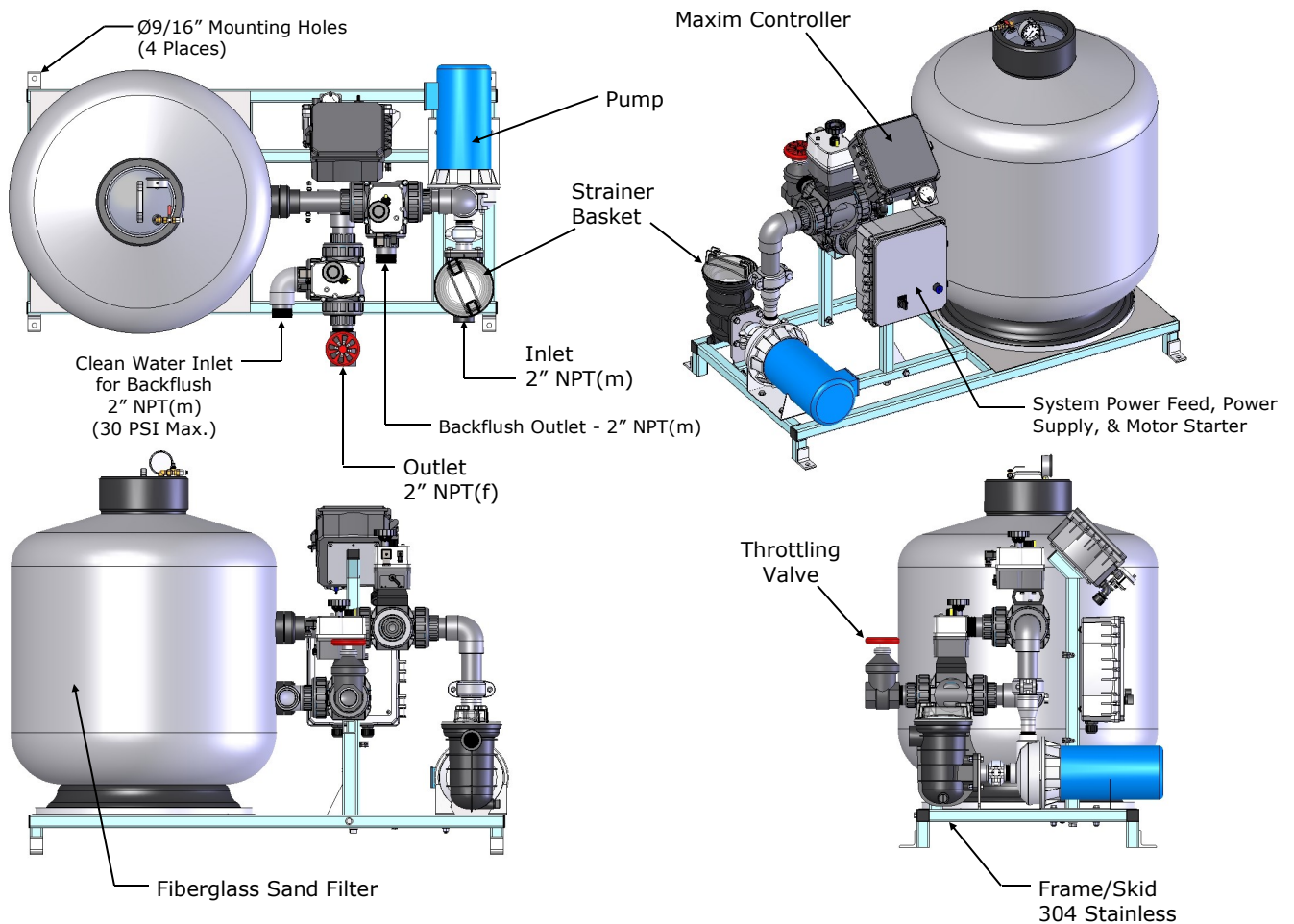

Figure 1. TowerGuard System Layout using the City Water backflush hookup.

## Modes of Operation

### **Filtration:**

During normal filtration, water is pumped to the filter via the internal riser pipe assembly and evenly distributed over the media. As the water travels down through the media bed into the under-drain, suspended particles are trapped. When the filter media requires cleaning, Miller-Leaman's *MAXIM* Controller will trigger a backflush cycle and automatically clean the filter. This may be triggered by the differential pressure sensor, the backflush timer, or manually by the user.

### **Backflush:**

Once a backflush is initiated, the pump will turn off and the valves rotate to their backflush position. The reverse flow lifts and churns the media bed creating a scouring action to release the captured debris. This debris is then flushed out of the backflush manifold. The filter is configured to be backflushed with source water from a city water supply. After the backflush cycle is completed, the valves rotate back to their original positions and normal filtration resumes.

# ***Installation Guidelines and Procedures***

Please carefully read the following procedures and guidelines for your system. Implementing these procedures and guidelines will prepare your TowerGuard Filter System for operation

## **Installation and Anchoring**

1. The *TowerGuard* Series filter system has been designed to easily lifted from the underneath the frame. If lifting straps are used, place them underneath the frame so they do not come in contact with any of the filter components. NEVER lift the system via any of the filter components.
2. The *TowerGuard* Series filter is designed for side-stream use only. The inlet to the system should draw from a non-pressurized location, such as a cooling tower sump. This system should NEVER be installed in a pressurized and/or full-flow application.
3. Each *TowerGuard* contains four anchor points. The system should be placed on a firm, supporting level surface and securely anchored. Miller-Leaman recommends that a concrete pad be poured for the filter frame to rest on.

## **Piping and Connections**

1. The TGSS-20, TGSS-24 and TGSS-30 *TowerGuards* suction pipe size should be one commercial pipe size larger the opening of pump inlet. Reducing the piping size may result in loss of flow. Make sure to support all piping to and from the filter to eliminate stress on the filter components.
2. Manual valves should be installed in each line to allow the system to be isolated for maintenance. However, the user must make sure that all valves are open prior to running the system. It is also recommended that unions be installed on each connection to allow for easier maintenance should the system ever have to be disconnected completely.
3. Connect the influent line from the sump to the pump. If the water level is below the pump inlet, a check valve or foot valve should be installed. The water inlet line should NOT exceed 10 PSI.
4. Connect the effluent line from the system outlet back to the cooling tower sump (or to sweeper piping). This line should not connect into a pressurized line.
5. Connect the backflush line from the port labeled "Backflush" to a drain. Do not place any valve or restriction in this line and make sure this line drains to a non-pressurized location. Be sure the drain is capable of handling the backflush flow rate. If not, a reservoir tank may be installed to collect the backflush water and allow it to slowly drain out.  
Make sure the dirty backflush water is properly disposed and meets all local code requirements.
6. Make sure the City backflush water supply line does NOT exceed 30 PSI. The end user is responsible for the addition of a pressure controlling device in the municipal water supply line to limit the inlet line pressure to 30 PSI maximum.

## Electrical Connections / Controls

1. Each *TowerGuard* requires a single point electrical connection to the pump motor starter box. See the Electrical Schematics in the Engineering Drawings section. See the system product specification or system identification label for the electrical requirements.
2. Insure the correct voltage and amperage is supplied to your system. Customer Power Supply should include a local disconnect that is fused or uses a circuit breaker sized to provide appropriate protection to the TowerGuard Filter System. Follow all local code requirements and NEC standards when installing field wiring. A Phase Sequence Indicator and Motor Rotation Tester should be used to determine the correct wiring for pump rotation. Also, see Initial Start Up Procedure, steps #9 & #10, on page 9.
3. The *TowerGuard* backflush is monitored and actuated by a *MAXIM* Controller. See the section on the *MAXIM* operation for a complete explanation of the controller functions and connections.

## Loading the Sand Media

The recommended sand is .45 to .55mm and meets the AWWA B100 requirement.

1. Before filling the filter media into the vessel, do a visual check of the laterals. Look for broken or loose laterals. Replace if necessary.
2. To eliminate stress on the laterals, fill the filter vessel with enough water to provide a cushioning effect when the sand is poured in.
3. For TGSS-20 and TGSS-24 inch Sand Filter models, Remove the top diffuser from the internal diffuser pipe and place the flexible air relief tube to the side and out of the way, inside the filter vessel. Cap the internal diffuser pipe with the sand shield that is provided to prevent sand from entering the pipe. DO NOT MOVE THE DIFFUSER PIPE, as this can affect the integrity of the bulkhead seal.

**NOTE - The above instructions do not apply to the TGSS-30 inch Sand Filter models. Any filter media entering the diffusers will be removed during normal filter operation.**

4. Wash all of the filter media and debris away from the threads of the filter vessel top cap area.
5. Thread the Top Cap onto the filter tank. Hand tighten only - do NOT use excessive force.

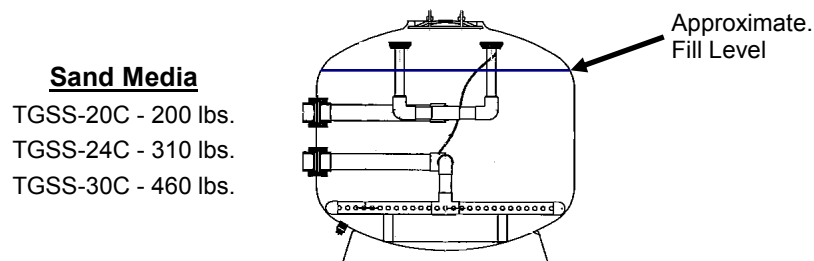

Figure 2.

## Replacing the Sand Media and/or under drains

1. While disassembly of the filter is unlikely to be required the following is relevant.
2. Ensure that the pump and water supply are turned off and all valves are in the off position.
3. Removal of the filter media can be done with the use of a slurry pump which will suck out the fluidized media. Remove the top manhole cover and ensure that there is sufficient water to fluidized the filter media so the slurry pump can be used, taking care not to break laterals while the last portion of media is being removed.
4. If a slurry pump is unavailable, open bottom drain, remove as much sand media as possible by hand, then flush remainder of the media out by adding water to the inside of the filtration unit.
5. The under drain stem and manifold can be replaced while in the filter. Under drain laterals unscrew from the manifold in sections to allow for removal and replacement.



# Startup and Shutdown

Prior to start-up, read and fully understand your *MAXIM* Owner's Manual section.

## Initial Start-up / Seasonal Re-start

Always inspect the filter system prior to start-up or after an extended shutdown period.

1. Before pressurizing the system, check that all clamps, bolts, lids, and system accessories are properly fastened.
2. Load the sand media - see procedure on page 8. (Disregard for seasonal re-start)
3. Open all isolation valves and allow the system to fill with water. Make sure the backflush drain is not restricted.
4. Prime the pump by filling the suction line and pump volute with water. If the main pump does not have a flooded suction, then a foot or check valve is required to maintain a prime after shutoff. For a flooded suction, prime the pump if needed.
5. *MAXIM* Controller Settings: With the pump starter switch OFF, turn the controller on by moving the controller switch to the ON position. Check the controller's settings by scrolling through the menu screens. See the controller recommendations in the **Adjustable Values** section. After verifying settings, scroll the menu to the Status: screen. At power turn on, the valves are allowed to rotate to the Filtration position. After 16 seconds, the Status will be AUTO.
6. Open the air vent located on top of the sand filter housing.
7. Refer to the System Labels on the Maxim Controller box. There is a duplicate label on the inside cover. Maximum operating pressure (50 PSI) and Maximum flow are listed on this label. These must be adhered to during start up.
8. Close the Outlet Throttle Valve by turning the handle fully clockwise, **then open the valve one and a half turns.**
9. Using the Pump switch "HAND", momentarily bump start the motor, when looking at the fan at the back of the motor, only long enough to verify that the motor is wired to rotate in the direction shown by the arrow.
10. After confirming that the motor is rotating in the right direction, start the pump.
11. While observing the pressure gauge on the top of the filter, rotate the Outlet Throttle Valve until the gauge is reading approximately 25 PSI.
12. Due to variances at site locations such as installation pipe sizes, pipe lengths, elevation, etc., the Outlet Throttle Valve may require further adjustment to optimize the desired flow. **Never exceed the specified maximum pressure or specified maximum flow.** Turn the pump OFF once the Outlet Throttle Valve has been adjusted properly.
13. Check the setting of the Pressure Differential Gauge. Factory and initial setting should be 12 PSID. See the Differential Pressure Gauge information in the Maxim Owner's Manual section.
14. Turn on the system by switching the starter to AUTO mode. AUTO mode will allow the controller to turn the pump ON/OFF as required. Note that the controller power switch must be ON in order for the pump to start.
15. Close the air vent once there is a steady stream of water.
16. Check all system components to ensure there are no leaks.
17. If the system has new sand media installed, run a complete backwash cycle. This will purge any excess fine particles from the system. To start a cycle, press OK on the controller's Status Screen. See the "**Monitoring the System Status and Initiating a Backflush**" section in the Maxim Owner's Manual section of this manual for information on normal Backflush sequence.
18. Once the backflush is complete, the system will automatically resume normal filtration.

## **Cold Weather Operation**

The *TowerGuard* Series filter does not come freeze protected. It is preferable to install the system in a heated room to prevent freezing. If this is not possible, the system should be properly protected with heat tape and insulation around all of the liquid filled components. The filter should be completely drained when not in use to prevent potential freeze damage.

## **Shutdown - For an extended length of time**

Follow the procedure below when the system will be shut down for a prolonged time period.

1. Run the filter through a complete backflush cycle to clean the sand media.
2. Turn off the pump and the controller, making sure the system is in normal filtration mode when turned off. Shut off and lock out all electrical power to the system.
3. Isolate the system by shutting off all valves that may allow water into the system. Open the air relief valve on top of the filter housing. Drain the system allowing all water to drain by removing the drain plug on the bottom of the filter. Replace the plug once the system is completely drained.
4. Remove the filter lid and inspect the overdrain assembly. Remove any foreign material from the media. Replace the media if necessary. Clean and lubricate the o-ring if necessary and reinstall the lid.
5. Close the air relief valve.

## **Recommended MAXIM Controller Settings**

*MAXIM* Controller - The controller should be monitored on a regular basis to make sure the system is operating normally. See the *MAXIM* Controller Owner's Manual in the following section for operating instructions. The controllers initial settings are factory preset at average values and do not necessarily reflect the individual needs for your system. Below are recommendations on how to adjust the controller to fit your system's needs.

- 1) The Pressure Differential (PD) gauge setting should be properly set once there is water flow in normal filtration mode. The recommended PD setpoint is 7 PSID above the "clean" gauge reading at the system's MAXIMUM flow rate. Typical PD gauge setpoints are between 12-15 PSID, depending on flow rate and filter size. Setting the PD gauge too low will cause the system to backflush too often, resulting in significant water loss to drain. The initial factory setting of the PD Gauge is 12 PSID. See additional PD Gauge info on page 14.
- 2) The backflush frequency setting should be adjusted so the system backflushes by elapsed time just before the system reaches it's pressure differential set-point. If the system is installed on an older tower, you may find the system backflushes frequently until the tower water has "cleaned up". We recommend the user begin with a 24 hour backflush frequency setting. This can be adjusted depending upon how often the pressure differential set-point is reached.
- 3) The backflush duration recommended initial setting is 60 seconds. This may be increased or decreased depending upon whether or not the backflush water is becoming clean by the end of the cycle. We do not however, recommend ever adjusting this value below 30 seconds. Take note of the original "clean filter pressure differential". When a backflush is complete, the Pressure Differential (PD) gauge reading should fall back to this level. If it is not returning to this level, you may want to increase the backflush time. If the problem continues, inspect the sand media and consider replacing it.

# Maintenance

A regular scheduled system maintenance program is important in keeping your system at it's best performance. Always follow start-up procedures after the system has been shut down for maintenance.

## Routine Inspection

- Visually inspect this system, looking for any leaks or unusual noises.
- Verify the pump is operating and that the pump inlet connection is secure. Also verify that the supply line is not blocked by debris or restricted in any way.
- Ensure that the controller is properly working, and that all backflush settings are properly adjusted. Check that the system is not backflushing too often by Pressure Differential (PD gauge).
- Check the system pressures. Make sure the Pressure Differential (PD) gauge is set at the correct PD setting and that it properly initiates a backflush. Be sure the system pressure never exceeds 50 PSI vessel pressure rating.
- Manually start a backflush to make sure both valves are actuating and the filter is backflushing properly.

## Seasonal Maintenance

- Remove the filter vessel cover. Check the sand media condition and replace if necessary. If the sand media is removed, inspect the internal piping assemblies. Clean and lubricate the O-ring before reattaching the cover.
- Inspect the system for any leaks. This should include all of the union couplings. The O-rings should be lubricated with silicon gasket grease to prevent them from drying and cracking.
- Check all of the 3-way valves to make sure they are operating properly. If the valves are not rotating correctly, remove the tops and inspect the motor / gears. Contact Miller-Leaman customer service if this condition exists.

## ***TowerGuard - City Backflush Model Spare Parts List***

TowerGuard - City Model Spare Parts List		
TGSS Part Number	Part Description	Qty per Filter
PS01328	20 inch Sand Filter Vessel - Complete Assembly	1
PS01329	24 inch Sand Filter Vessel - Complete Assembly	1
PS01330	30 inch Sand Filter Vessel - Complete Assembly	1
ML21327	Outlet Gate Valve Assembly	1
PS00034	Pressure Gauge 150 PSI range	1
ML21354-01	Differential Pressure Gauge 15 PSID range	1
PS00411-1HP-1P	1HP - 43GPM 1 Phase Pump (115/230VAC)	1*
PS00411-1HP	1HP - 43GPM 3 Phase Pump	1*
PS00295-1.5D1P	1.5 HP - 62GPM 1 Phase Pump (115/230VAC)	1*
PS00295-1.5D	1.5 HP - 62GPM 3 Phase Pump	1*
PS00295-2C1P	2HP - 98GPM 1 Phase Pump (115/230VAC)	1*
PS00295-2C	2HP - 98GPM 3 Phase Pump	1*
PS00373	Mechanical Seal for NPE Series Pumps	1
PS01827	Trap Assembly, Pump Pre Filter	1
ML22246	Actuator Flow Valve Assembly - City model	2
ML20295-22	Motor Starter Box - Complete Assembly	1
ML20639-08T	MAXIM-8 Controller box - City model (Power Supply in Str.Box)	1

**Figure 3** - TowerGuard - City Backflush Model Spare Parts List

\* Note - Selection is System dependant.



## TowerGuard Side Mount Sand Filter

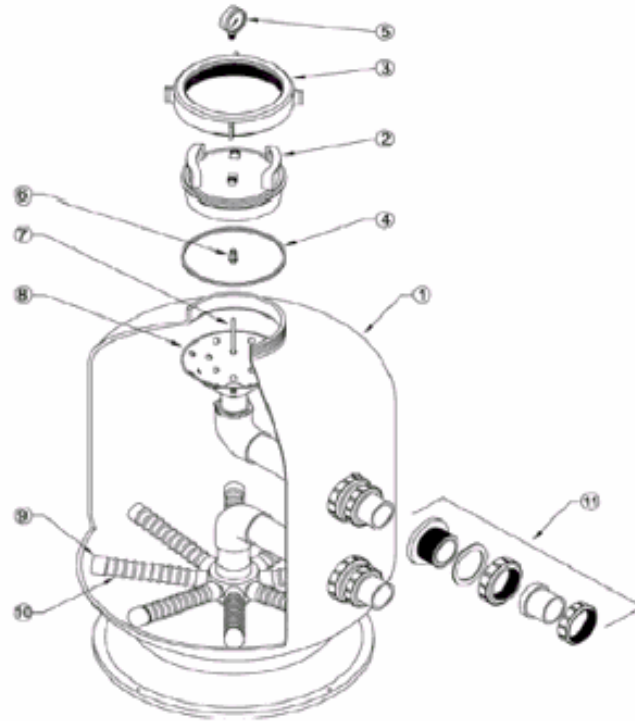

SM Series Sand Filters			
Key No.	Part No.	Part Description	Qty Per Pump
1	22000820L	Filter Shell only 20" (SM500)	1
	22000824L	Filter Shell only 24" (SM600)	1
	22000830L	Filter Shell only 30" (SM750)	1
	22000836L	Filter Shell only 36" (SM900)	1
2	6209291	Lid 8" Clear	1
3	62024BLK	Top Lid Locking Ring	1
4	62026	Top Lid O-Ring 8"	1
5	30B3000	Pressure Gauge	1
6	W04190	Air Bleed Screen	1
7	W02654	Air Bleed Assembly	1
8	620940	Water Diffuser	1
9	See Lateral Chart		
10	See Lateral Chart		
11	W12610	Port Assembly 1-1/2"	2
	W04006BLK	Port Assembly 2"	2
11A	W02272BLK	1-1/2" Port Fitting	2
	W02568	2" Port Fitting	2
11B	W02268	1-1/2" Port Gasket	2
	W02080	2" Port Gasket	2
11C	W02271BLK	1-1/2" Port Nut	2
	W02567	2" Port Nut	2
11D	122243B	1-1/2" Union Half w/ O-Ring	2
	634024BLK	2" Union Half w/ O-Ring	2
12	620221	Air Relief Valve (NS)	1
13	W02026BLK	Drain Assembly (NS)	1

Laterals			
Key No.	Part No.	Part Description	Qty Per Pump
9	W02111	Lateral 3 1/2" Long	8
9	W02112	Lateral 4 1/2" Long	8
9	W02113	Lateral 5 1/2" Long	8
9	W02114	Lateral 8" Long	8
10	W02117	Lateral Cap	8

Figure 5 - TowerGuard Sand Filter Vessel Parts List

# MAXIM - State-of-the-art Filter Backflush Controller

## Introduction

The TowerGuard Filter System is controlled by the *MAXIM*, a state-of-the-art backflush controller designed for automatic filtration systems. The heart of the *MAXIM* is a programmable micro PLC, custom designed to maximize the performance of your filtration system. These components are protected by a robust, corrosion-proof watertight enclosure.

The *MAXIM* is operated and adjusted through the user-friendly menu screens that give the user control of all critical automatic filter functions. The backlit LCD display provides real-time system status. The controller includes a memory module (EEPROM) port that allows for installation of system upgrades and provides the ability to download custom, application specific programs without the need for a computer.



## Installation

The *MAXIM* controller is pre-installed as a component of the complete TowerGuard filtration system. Follow the directions below only if it is necessary to connect electrical or gauge connections.

### Electrical Connections:

The Maxim controller is pre-wired as part of the Automatic TowerGuard Filter System.

**Note:** When using an external power source, the input power to the PC Board must be the same as indicated on the upper left side of the Maxim Controller. Typically, the controller is either 24 volts AC, or 24 volts DC, however some controllers use 120 volts AC or 12 volts DC.

Additional connections to the Outputs should be made to the corresponding *Output (+)* and a *Common (-)* terminal on the circuit board. The Pressure Differential Gauge and Timer ON Enable inputs are connected to a corresponding Input and Auxiliary Power Out (+) terminal on the Maxim circuit board.

Review the *Electrical Detail* section prior to making any connections to the controller. If requested custom input/output capabilities are not described in this manual, please refer to an attached addendum.

### Differential Pressure Gauge Connections:

Connect the pressure differential (PD) gauge to the system's inlet (high/BLK) and outlet (low/BLU) pressure ports.

**WARNING:** Failure to use a second wrench on the low pressure port when tightening fittings may result in damage to the internal pressure tubing.

Be sure all connection tubing is clean prior to installation on the gauge. The gauge contains orifices that may become clogged by larger particles.

**CAUTION:** Make sure not to foul the pressure orifices with pipe dope or dirt, as the gauge will not operate.

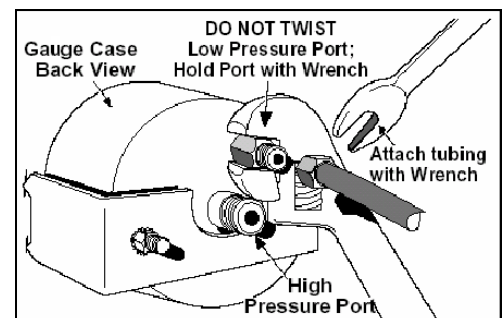

### Differential Pressure Gauge Set-point:

Adjust the front face needle contact to the desired PD set-point that will trigger a backflush cycle. The recommended PD setpoint is 8-10 PSID above the "clean" gauge reading at the systems MAXIMUM flow rate. Setting this gauge at low flow may result in continuous backflushing at higher flow rates, since the Pressure Differential increases with flow rate. Typical PD gauge setpoints are between 12-15 PSID, depending on the flow rate. Initial factory PD Gauge setting is 12 PSID.



## Electrical Detail

The circuit board layout shown applies to the M8 controllers. The M# in the serial number on the left side of the enclosure designates the controller's total number of outputs. For example, a MLI-M8-xxxxx has 8 available outputs (uses outputs 1-8 only, leaving outputs 9 and 10 unused). Review the connection details below before wiring to the controller.

**CAUTION: Unplug controller from power source before removing cover!**

### A. Power supply connections:

- *115VAC Power In* - used only on previous Maxim versions. The Power Supply is now located in the Starter Box.
- *12VDC/24VDC/24VAC Power In* provides power to the controller and circuit board connections. This power is typically provided from the Power Supply located in the Starter Box.

Note: The standard Power Supply provides a maximum total power output as listed below. Exceeding the maximum available power may trip the fuse repeatedly or overload the Power Supply. The fuse is an automatic resetting type and will reset itself within a few seconds of being tripped. The overloaded Power Supply will shut down for a few seconds, then re-power and re-check if the overload / overcurrent condition still exists. (See Power Up Sequence on page 15)

Maximum power available: 12VDC or 24VDC - 24 Watts; 24VAC - 48 Watts

### B. Outputs:

The outputs provide a voltage output (same as controller's voltage) to control the backflush valves, pump starter, etc.

Note: Any *Common (-)* connection may be used for the common/negative terminals of the solenoids/valves.

- Output 1: Upper Backflush valve actuates CW for Filtration flow. This output is activated after backflushing is complete to return water to normal flow. (Note - delayed for 2 sec. after Output 5 starts)
- Output 2: Upper Backflush valve actuate CCW for Backflush flow. This output is activated at the beginning of a backflush cycle to reverse water flow through the filter.
- Output 4: Pump Starter. This turns the pump off while the valves are changing positions and during the entire backflush cycle. The pump must be operated in "Auto" mode for this to occur.
- Output 5: Lower Backflush valve actuates CW for Filtration flow. This output is activated after backflushing is complete to return water to normal flow.
- Output 6: Lower Backflush valve actuate CCW for Backflush flow. This output is activated at the beginning of a backflush cycle to reverse water flow through the filter. (Note - delayed for 2 sec. after Output 2 starts)
- Output 7: System Alarm Output - a relay output to signal a System Alarm (See System Alarm on page 18).
- Output 8: Backflush Master - a relay output to signal a Backflush cycle is in progress.

### C. Inputs:

The inputs provide signals into the controller. Digital (on/off) inputs require a voltage input that matches the controller's operating voltage. The controller inputs are listed below.

Standard Inputs:

- Input 1 #I1 PD Gauge - *I1* and *Auxiliary Power Out* (+) are connected to Normally Open contacts on the PD gauge. Once the PD set-point is reached, the contacts will close and signal the controller.
- Input 2 #I2 Backflush Timer Enable input. *I2* and *Auxiliary Power Out* (+) are connected to a Normally Open Auxiliary Contact on the Main Pump. This signal is the Status: AUTO for Filtration signal.

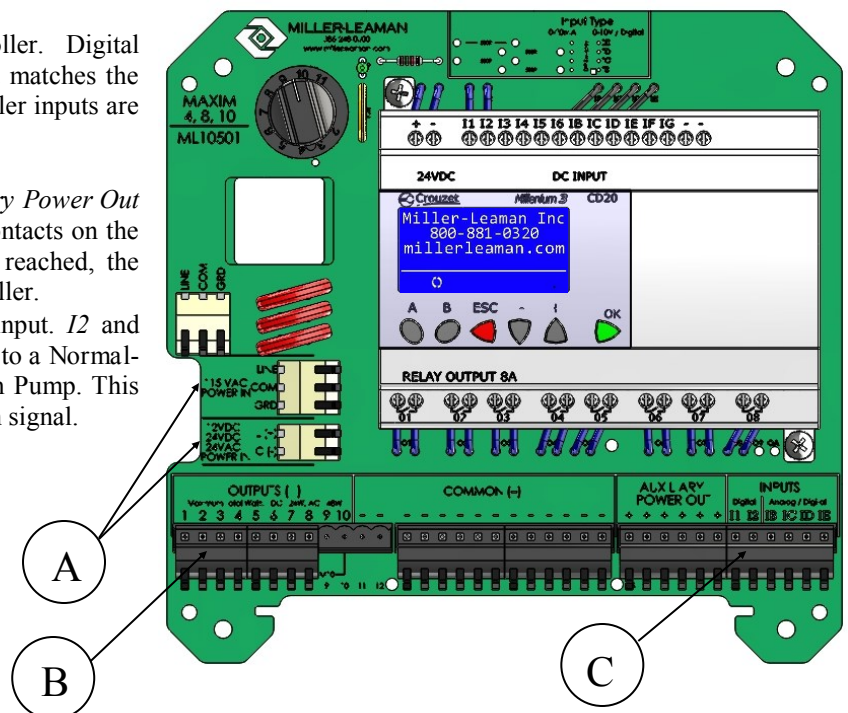

## Viewing the Menu Screens & Adjusting Values

### Scrolling through Menu Screens

The *MAXIM* controller allows the operator to scroll through a selection of menu screens by pressing the **A** or **B** buttons. Press **A** to scroll backward to the previous menu or press **B** to scroll forward to the next menu. The LCD backlight will automatically turn on for 5 minutes when a button is pressed, thus allowing the operator to easily view the menus in low light situations.

**Initial Power Up Screen Sequence** - after first turning on the Maxim Controller, or after a restart caused by a loss of power, this will be the screen sequence that is displayed.

**Initial Power Up Screen** - the company contact information, or Screen 08, is displayed for the first 5 seconds. This allows time for controller initialization while the pump is turned off for the valves to be turned back to the filtration position.



**Status: ON Valves to Filtration Screen** - after the pump has been turned off the valves will be turned back to the filtration position, or closed. This will take approximately 16 seconds. During this time the display will be changed to the Status Screen, or Screen 01, which will indicate that the Valves are being moved to the Filtration position.

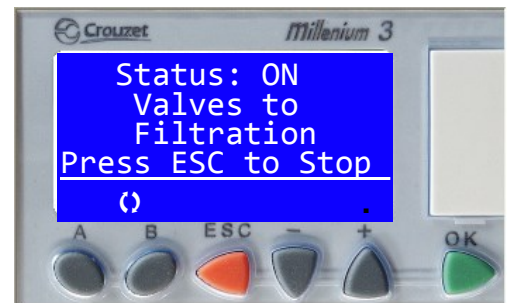

**Company Contact Information Screen** - after 16 seconds, the Valves will be closed, or in the Filtration position. The Display is changed back to the company contact information, or Screen 08. The pump will be turned on and normal filtration will resume. Press the B button to scroll forward to the Status screen.



This next section describes the menus in the order they are seen by scrolling with the B button from the Company Contact Information Screen at the completion of the Initial Power Up Sequence.



**Screen 1 - Status**



**Screen 2 - City Water**



**Screen 3 - BF Interval**



**Screen 4 - BF Duration**

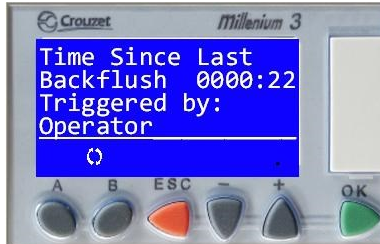

**Screen 5 - Time Since Last  
BF & Triggered By**



**Screen 6 - BF Counters  
Trip & Life**



**Screen 7 - Machine &  
Controller ID**



**Screen 8 - Company  
Contact Information**

Note - pressing the B button to scroll forward from screen 8 - Company Contact Information screen, causes the display to cycle back around to the beginning and display the Screen 1 - Status Screen. Also pressing the A button to scroll backwards from Screen 1 - Status screen, causes the display to cycle back around to the end and display the Screen 8 - Company Contact Information screen.



# Adjustable Values

## Changing Values

To change an adjustable value, first scroll to the appropriate menu screen using the **A** or **B** button. Follow the directions below to modify the value.

1. The current selected value will show flashing blocks. Use the + or - keys to select another value if desired.
2. Press **OK** on the selected value. The value will change from flashing blocks to flashing numbers.  
  
(Flashing blocks indicate the value is locked into memory. Flashing numbers indicates the value is unlocked and can be changed.)
3. Press the + or - buttons to change the value.  
  
(Holding the + or - button will allow the value to increase at a faster rate after the first 10 increments have passed.)
4. When finished, press **OK** to save the change to memory. The value will return to flashing blocks.
5. Press the **OK** button a second time to save the value.

The following screens contain values that are operator adjustable. The controller's factory preset values may not be the final operating values. These values should be adjusted to meet the filters backflush requirements. Reference the filter manufacturer's owners manual for additional information.

**Backflush Interval:** The user-defined interval at which the system will initiate an automatic backflush cycle. The backflush Interval timer resets after any backflush cycle occurs (by timer, PD gauge, or operator). This value is adjustable from 1 minute to 1000 hrs. Setting both values to zero will turn off the backflush timer. It is recommended that the operator adjust the backflush interval timer so that the system backflushes by the time before the pressure differential is reached. Factory Preset value is 24 hours.

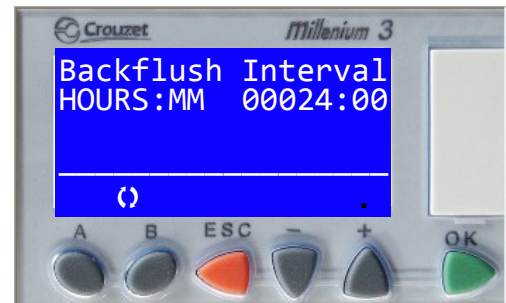

**Backflush Duration:** The time allotted for the actual backflushing of the filter once the valves have been opened to the backflush position. This time is set according to the type of filter and the nature of the material being filtered. This value is adjustable from 1.0 to 600.0 seconds. Factory Preset value is 180.0 seconds.

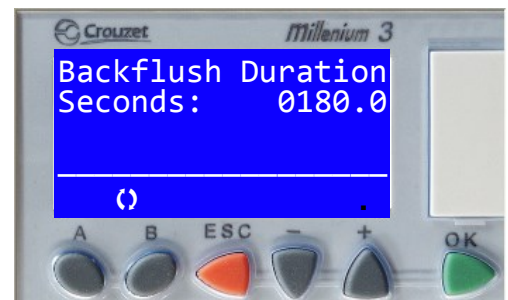

## Monitoring the System Status & Initiating a Backflush

The Status Screen displays the current mode of the controller. It also allows the operator to manually start or stop a backflush cycle. There are three ways that a backflush cycle can be initiated:

1. Manually, following the instructions below.
2. Automatically, by elapsed time (per the backflush frequency setting).
3. Automatically, by pressure differential (as set by the PD switch-gauge).

To initiate a manual backflush, press the **OK** button while on the status screen. At any time during the backflush cycle, press the **ESC** button to stop the cycle.

The controller will automatically display the status screen if a backflush cycle is initiated or if the pressure differential set-point is reached.

The current **Status** of the controller is displayed as follows:

1. **AUTO** - Indicates that the controller is waiting for a backflush cycle to begin. The system is in normal filtration mode and flowing water. The backflush frequency timer is running.
2. **AUTO - High PSID** - Indicates that a high pressure differential from the PD Gauge has been sensed and that the controller is about to start a backflush cycle.
3. **ON** - Indicates that the system is in backflush mode.

**Valves to Backflush** is displayed at the beginning of a backflush cycle as the valves are redirecting water from normal flow to backflush flow. The controller will automatically turn the pump off for the duration of the Backflush cycle. City Water is used for the Backflush.

**Backflushing System** is displayed when the City Water is cycling through the system in backflush mode.

**Valves to Filtration** is displayed at the end of a backflush cycle as the valves are returning to normal flow positions. The controller will automatically turn the pump back on after it has changed the valve positions to Filtration.

Note - The **Status: ON Valves to Filtration** screen is also displayed in the Initial Power Up Sequence. To insure proper filtration in the event of a power failure, the valves are assumed to be in a non filtration position, the pump is turned off, and the valves moved to the filtration position. Then the pump is turned on and normal filtration is resumed.

4. **ON - System Alarm** - On any of the Status screens a System Alarm screen can be activated. The second line down will alternately flash >> **System Alarm** << and whatever was on line 2 before the alarm occurred. The standard system alarm is the Consecutive Backflush Alarm. This alarm occurs when the backflush cycle has been initiated three times in a row by the Pressure Differential Switch (PSID). The Operator should verify proper operation of the PSID. The System Alarm can be reset by pushing the red ESC button while a status screen is dis-

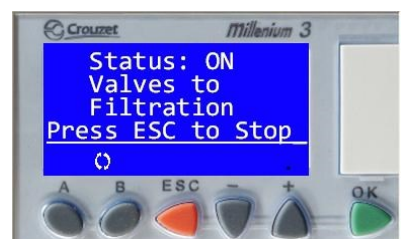

## Controller Feedback

The following screens provide system feedback. This allows the operator to monitor when and how the backflush cycle is occurring. It is recommended that the operator adjust the backflush interval timer so that the system backflushes by time before the pressure differential set-point is reached.

### Backflush Counter:

The number of backflush cycles that have occurred since the counter was last reset. This includes cycles initiated both manually and automatically. This counter can be reset by pressing the **ESC** button from the *Backflush Counter* screen.

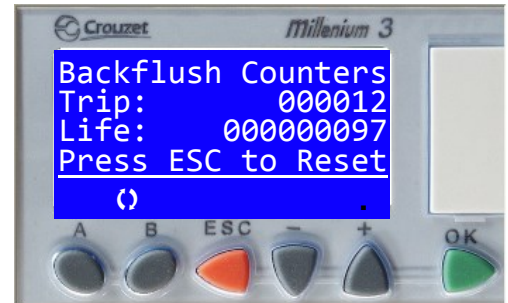

Time Since Last Backflush: The amount of time that has elapsed since the system last backflushed. The time displayed is in hours and minutes. This value does not include the elapsed time when the backflush frequency timer is off (either when the Status Screen reads “*Status: Off*” or when the controller is physically switched off).

This screen also displays how the last backflush was triggered. There are three possibilities:

- 1) *Operator* - the backflush was manually triggered by an operator via the status screen.
- 2) *Timer* - the backflush was triggered by time as set on the backflush frequency screen.
- 3) *PD gauge* - the backflush was triggered by a high pressure differential, as set on the PD gauge mounted below the controller enclosure.

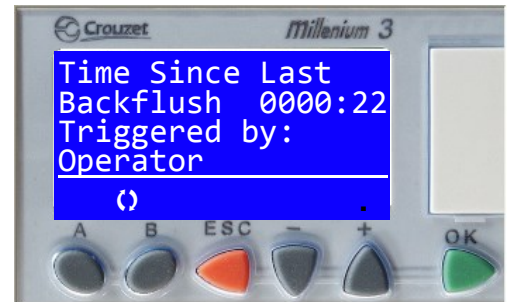

City Water Backflush: The type of water used for backflushing the system.

**Note:** The controller’s internal settings are set for City Water Backflush only. This setting is Read only, and has no user adjustment.



# Limited Warranty

**1) Duration:**

One year from the date of purchase by the original purchaser.

**2) Who gives this warranty (Warrantor)**

Miller-Leaman Incorporated / 800 Orange Avenue / Daytona Beach, FL 32114, (386) 248-0500.

**3) Who receives this warranty (Purchaser):**

The original purchaser (other than for purposes of resale) of the Miller-Leaman product.

**4) What products are covered by this warranty:**

Any Miller-Leaman *TowerGuard* housing and filter system components manufactured or sold by the warrantor. The sand media is excluded from this warranty.

**5) What is covered under this warranty:**

Defects on materials and workmanship, which occurs within the duration of the warranty period.

**6) What is not covered under this warranty:**

**A)** Implied warranties, including those of merchantability and fitness for a particular purpose, are limited to one year from the date of original purchase. Some states do not allow limitations on how long an implied warranty lasts, so the above limitations may not apply to you.

**B)** Any incidental, indirect, or consequential loss, damage, or expense that may result from any defect, failure, or malfunction of the Miller-Leaman product. Some states do not allow the exclusion or limitation of incidental or consequential damages, so the above limitation or exclusion may not apply to you.

**C)** Any failure that results from an accident, purchaser's abuse, neglect, or failure to operate the products in accordance with the instructions provided in the owner's manual supplied with the product.

**D)** Items or service that are normally required to maintain the product, i.e. gaskets.

**7) Responsibilities of warrantor under this warranty:**

Repair or replace, at warrantor's option, products or components which have failed within the duration of the warranty period.

**8) Responsibilities of purchaser under this warranty:**

**A)** Deliver or ship the Miller-Leaman product to the Miller-Leaman manufacturing facility. Freight costs, if any, must be borne by the purchaser.

**B)** Use reasonable care in the operation and maintenance of the product as described in the owner's manual.

**9) When the warrantor will perform repair or replacement under warranty.**

**A)** Repair or replacement will be scheduled and serviced according to the normal workflow at the manufacturing facility, and depending on the availability of replacement parts.

**B)** If the purchaser does not receive satisfactory results from the product repair or replacement, the purchaser shall contact Miller-Leaman immediately.

***NOTE: THIS WARRANTY IS VOID IN THE EVENT THE PURCHASER FAILS TO COMPLY WITH ANY ONE OF THE REQUIREMENTS FOR INSTALLATION AND USE OUTLINED OR SET FORTH IN THIS MANUAL AND MILLER-LEAMAN INCORPORATED ASSUMES NO LIABILITY WHATSOEVER.***

**This Limited Warranty gives you specific legal rights and you may also have other rights which vary from state to state.**



800 Orange Avenue, Daytona Beach, FL 32114

Phone: (386) 248-0500 / Fax: (386) 248-3033

[www.millerleaman.com](http://www.millerleaman.com)

email: [sales@millerleaman.com](mailto:sales@millerleaman.com)

Hours: M-F 8:00 AM - 5:00 PM Eastern USA

