

<p>DFC81 7H'GD97= =75H=CB</p>	<p>8F5K B @6UbbUb)#& #& 7<97?98</p>		<p>GMGH9A F9E1 =F9A 9BHG. 9YVWfVW: (*\$J57# D\# \$<n# 5 GrghYa 'DrYggi fY.) \$'DG="A UI " DFYggi fY4 6UWk Ug. " \$'DG="A UI " 8fmK h) * \$'Vg #C dYfUhb['K h '&* - &'Vg fK #A YX]Uk AYX]U fYe. **\$ \$'Vg 9gh'</p>	<p>H-H@9. Hck Yf; i UfX H; !GG!' \$7!D- , !' D! 6 A YX]U:]hyf 'G_X' GrghYa fl gb['7]miK UhYf 'Zcf' 6UW_Zi gL</p>
<p>O KNGT' NGCO CP <small>HP E</small></p> <p>, \$ \$'CfUb[Y'5] Y''8UntcbU'6YUW : @' &%(</p>	<p>9B; '5DDF" A?H'5DDF"</p>	<p>G<99H'cZ&FYZ A @&&(, %' \$7!' D! 6 FY] . 7</p>		

657?K 5G<'CI H@9H
&"Fc"YX"; fccj Y
k #6i HhYfZmH\fcH]b[
JUj Y7

7-HMK 5H9F '-B@9H
&"Fc"YX"; fccj YX'
7cbbYVW]cb
k #DfYggi fY'; Ui [Y
k #6U"JUj Y

-B@9H
%d%#&"BDHFZ
k #DFY'GhfU]bYf
HfUd

CI H@9Hz'&"
Fc"YX"; fccj Y
k #6i HhYfZmH\fcH]b[
JUj Y

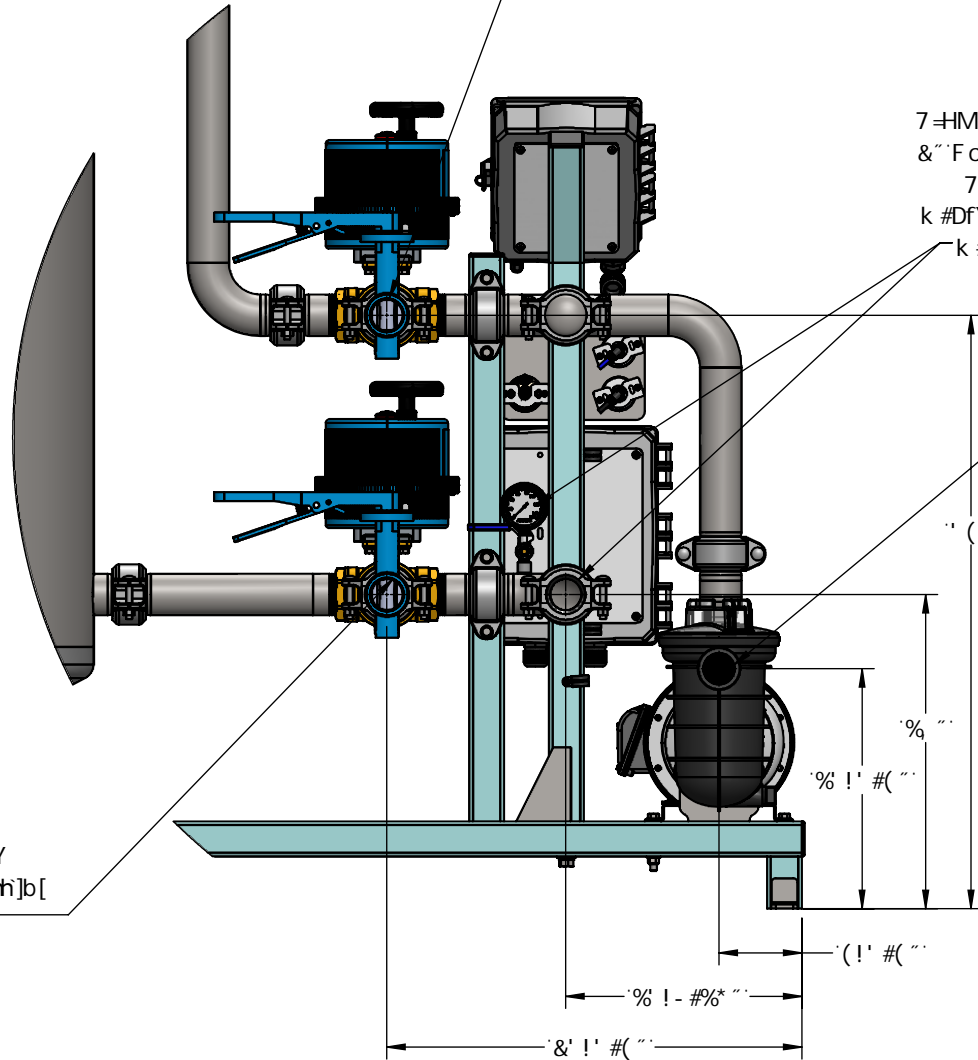

89H5=@5

DFC8I 7H'GD97=: =75H=CB

O KNGT' NGCO CP HP/E

, \$\$'CfUb[Y'5j Y"8UntcbU'6YUW ': @' &%(

8F5K B	@6fUbbUb	, #9 #8
7<97?98		
9B; '5DDF"		
A?H'5DDF"		
G<99H &cZ&FYZ A&&(&, %d' \$7!' D!6		FYj !!!

GMGH9A F9EI =F9A 9BHG.
9YVf]W'. B#5
5]f'Gi dd'm' B#5
K UHf'Gi dd'm4 'b'Yh' B#5
8fmK Y] [\h' B#5
Jci a Y. B#5

H-H@9.

Hck Yf; i UfX
H; !GG!' \$7!D-, !' D!6
A YX]U:]hYf'G_]X'GmghYa
fl g]b['7]lmK UHf'Zcf'6UW_Zi g\k