

GENERAL SPECIFICATIONS:

- Maximum Flow: 350 GPM (No minimum flow requirement)
- Maximum Pressure: 125 PSI
- Maximum Temperature: 135° F
- Screen Surface Area 367 Sq. In.

MATERIALS:

- Housing: 316 Stainless Steel
- Gasket: EPDM (other compounds available)
- Screen Mesh: 316 Stainless (1/4" perforated sheet backup)
- Clamp: 301, 302, or 304 Stainless

SCREEN OPTIONS:

- Multiple screen mesh and perforated sheet sizes available. (See product catalog for samples)

NOTES:

- 1- Dimensions are for informational purposes only and are subject to change.
- 2- 45" overall height is required for filter element removal.

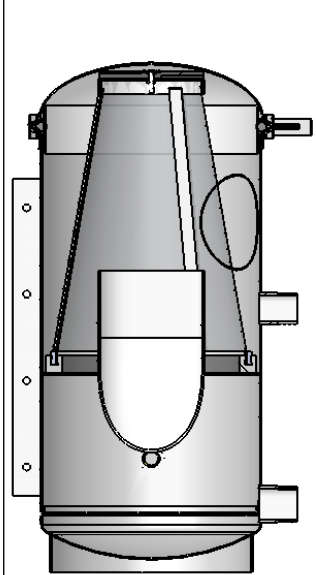

SECTION A-A

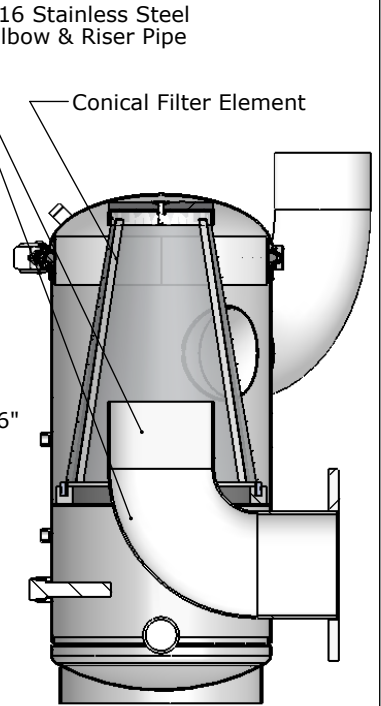
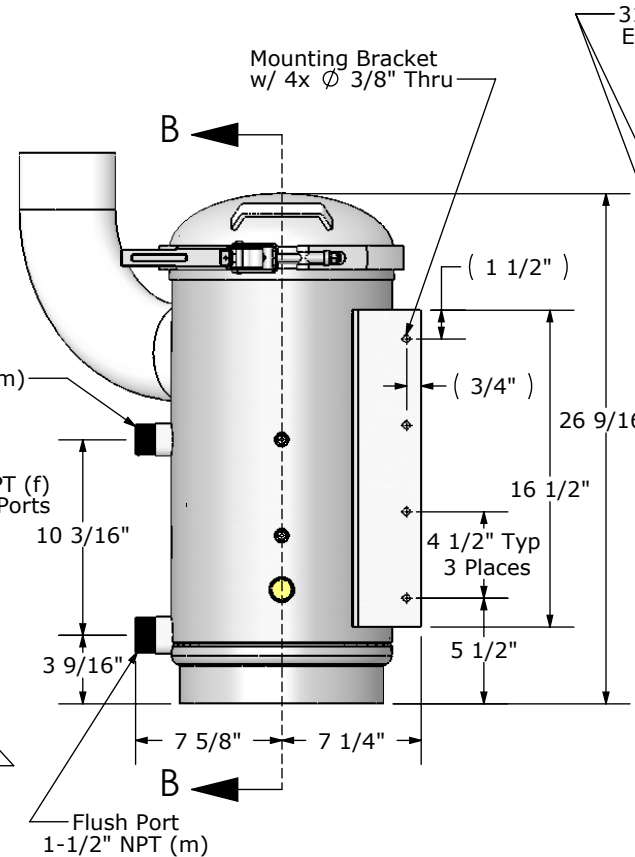
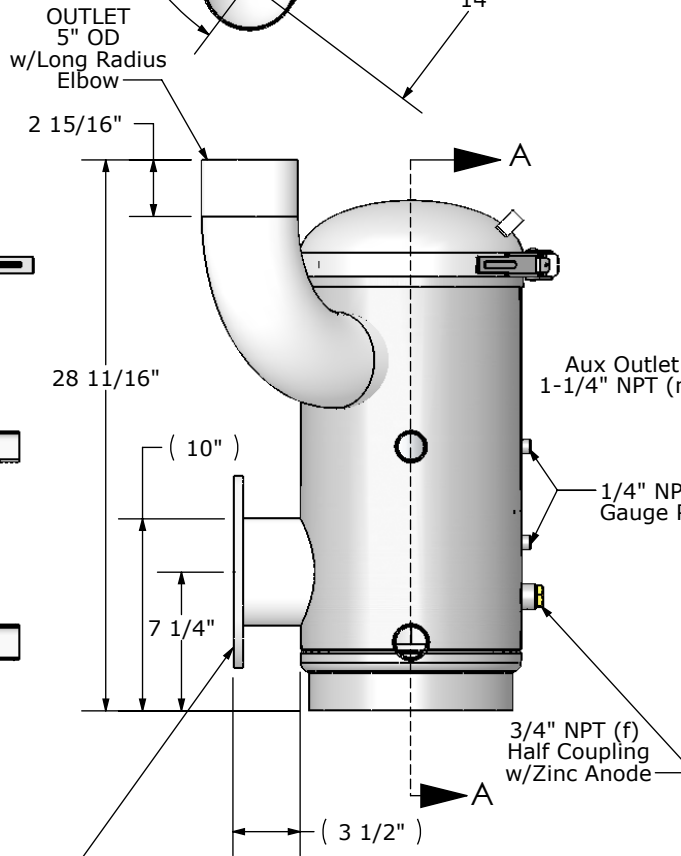

SECTION B-B

INLET, 5" 150lb Flange

PRODUCT SPECIFICATION

MILLER-LEAMAN INC.

800 Orange Ave. Daytona Beach FL 32114

DRAWN	L.Brannan	6/29/09
CHECKED		
ENG APPR.		
MKT APPR.		
SHEET 1 OF 1		

TITLE

**Thompson Strainer
MLS-4C-T316-MOD36**