

1/4" Thick Head Flanges (2)

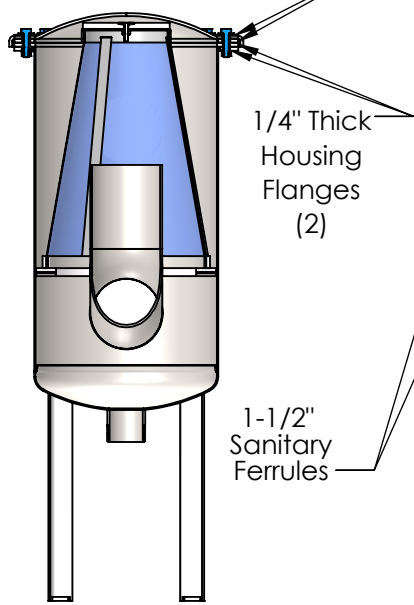

SECTION A-A

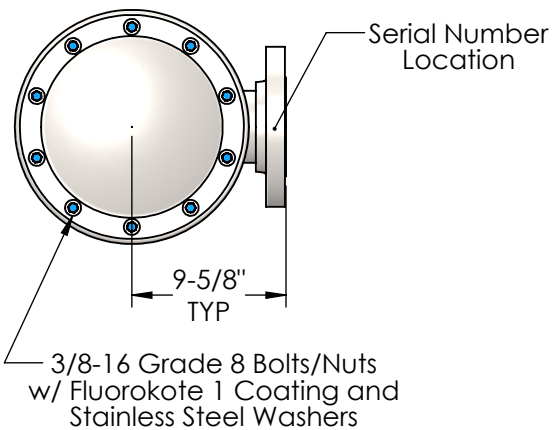
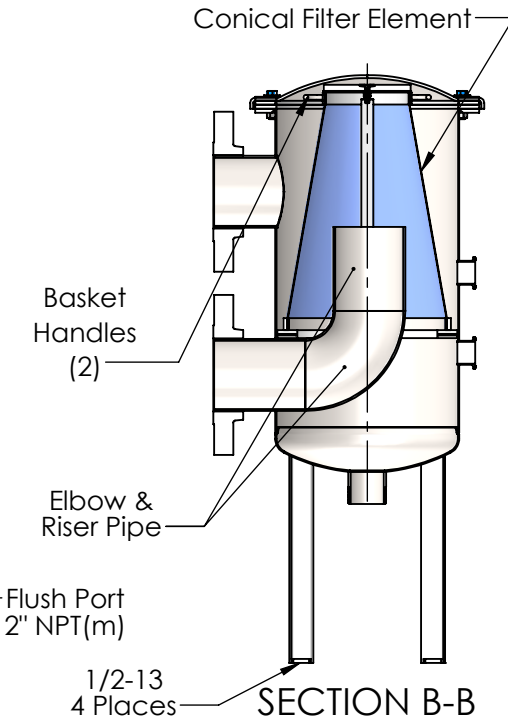
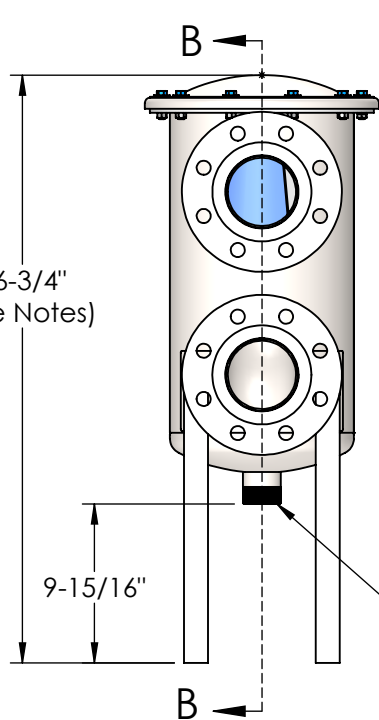
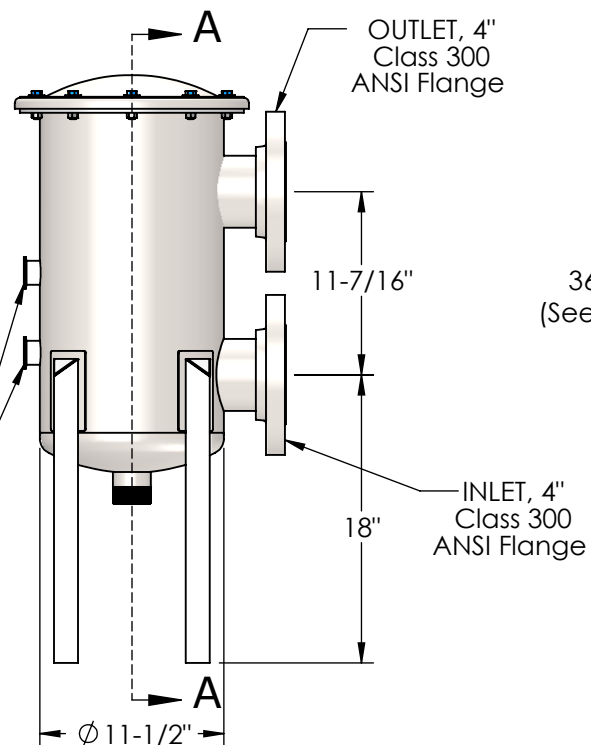

SECTION B-B

GENERAL SPECIFICATIONS	
DESIGN FLOW (GPM)	350
MAX PRESSURE (PSI)	150
FILTRATION AREA (SQ IN)	367
DRY WEIGHT (LBS)	120
VOLUME (US GAL)	11
MAX TEMP (°F)	176

MATERIALS		
HOUSING / SCREEN FRAME		304SS
SCREEN		316SS
GASKETS		BUNA-N (FDA)
ELBOW & RISER PIPE		304SS
CONICAL FILTER ELEMENT		
PERFORATED SCREEN		TBD
MESH SCREEN		TBD
SCREEN HEIGHT (IN)		15.91

NOTES

CLEARANCE ABOVE STRAINER EQUAL TO SCREEN HEIGHT REQUIRED FOR SERVICE

WARNING!
Exposure to high temperature water or equipment can cause serious injury or death. Proper thermal protection safeguards and PPE practices must be utilized.

Seller: _____
End User: _____



PRODUCT SPECIFICATION



800 Orange Avenue, Daytona Beach, FL 32114

Dimensions are for reference only.

CUST. REF.	
PREV. MOD.	MLS-4B-HT-MOD72
ENG. REF.	ML20252-MOD72
DWG. DATE	1/3/22
	SHEET 1 of 1

SERIES:	THOMPSON	MODEL:	STRAINER
CONFIGURATION:		MLS-04B-FSR5-304B-M1	