

GENERAL SPECIFICATIONS	
DESIGN FLOW (GPM)	350
MAX PRESSURE (PSI)	150
FILTRATION AREA (SQ IN)	367
DRY WEIGHT (LBS)	129
VOLUME (US GAL)	11
MAX TEMP (°F)	TBD

MATERIALS		
HOUSING / SCREEN FRAME		304SS
SCREEN		316SS
GASKETS		EPDM
ELBOW & RISER PIPE		304SS
CONICAL FILTER ELEMENT		
PERFORATED SCREEN		TBD
MESH SCREEN		TBD
SCREEN HEIGHT (IN)		16.75

NOTES

CLEARANCE ABOVE STRAINER EQUAL TO SCREEN HEIGHT REQUIRED FOR SERVICE

WARNING!
Exposure to high temperature water or equipment can cause serious injury or death. Proper thermal protection safeguards and PPE practices must be utilized.

Seller: _____

End User: _____

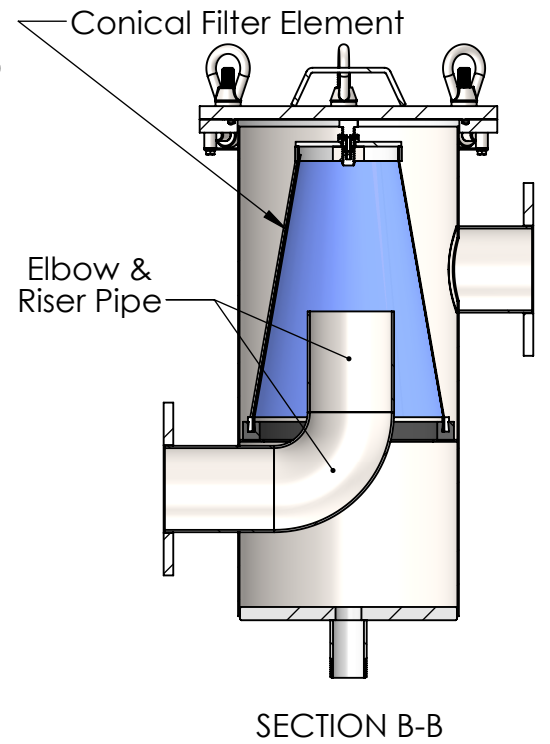
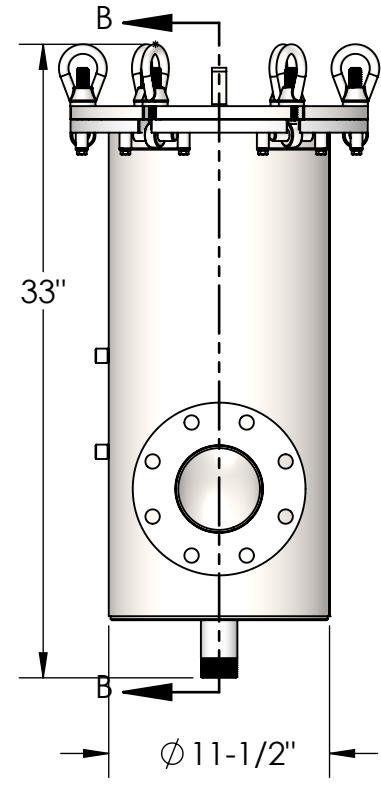
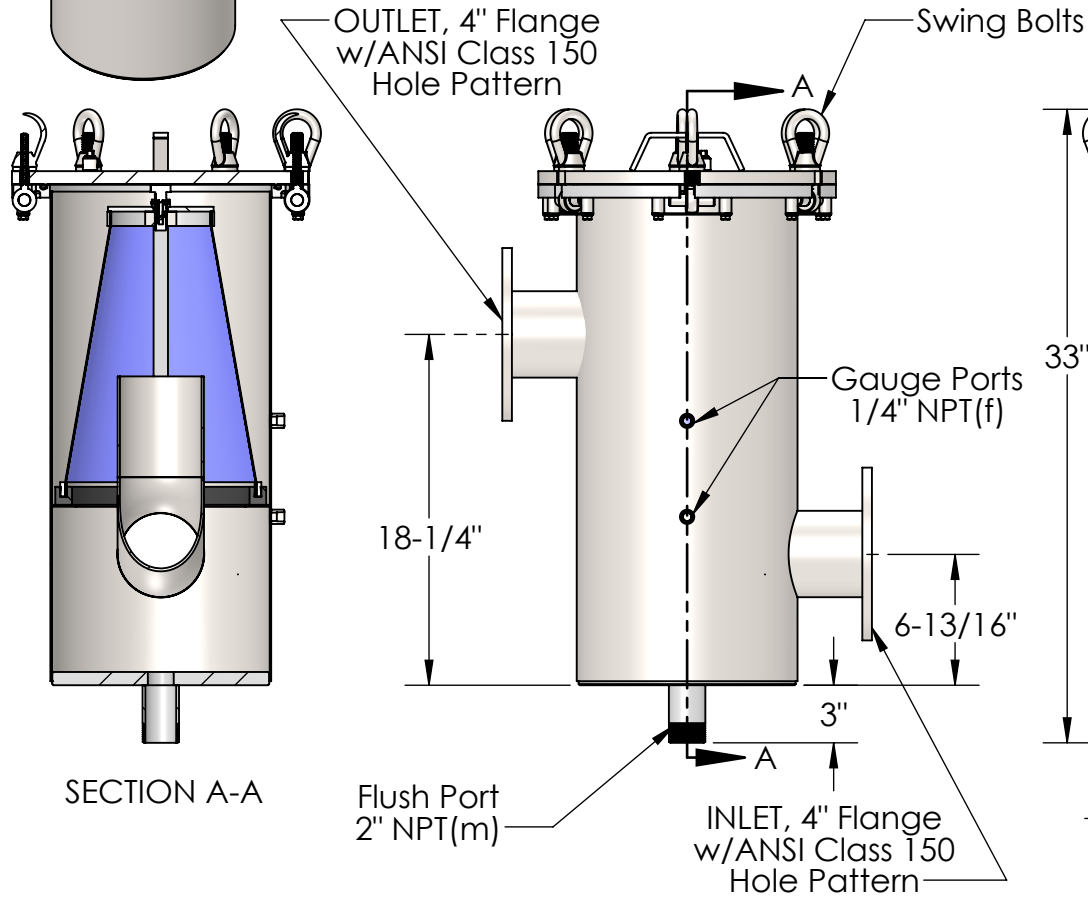

PRODUCT SPECIFICATION

MILLER LEAMAN

800 Orange Avenue, Daytona Beach, FL 32114

Dimensions are for reference only.	
CUST. REF.	
PREV. MOD.	N/A
ENG. REF.	ML23016-MOD1
DWG. DATE	6/11/21
	SHEET 1 of 1

SERIES: THOMPSON
MODEL: STRAINER

CONFIGURATION:
MLS-04S-FS3-304E-M1