

Serial Number Location

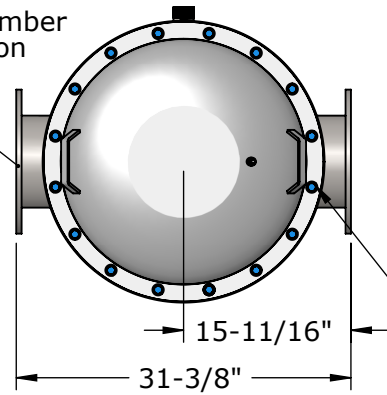

1/2-13 Grade 8 Bolts/Nuts
& SAE High Strength Washers
w/FluoroKote 1 Coating

GENERAL SPECIFICATIONS	
DESIGN FLOW (GPM)	1300
MAX PRESSURE (PSI)	150
FILTRATION AREA (SQ IN)	1559
DRY WEIGHT (LBS)	222
VOLUME (US GAL)	82
MAX TEMP (°F)	TBD

MATERIALS		
HOUSING / SCREEN FRAME		304SS
SCREEN		316SS
GASKETS		EPDM
ELBOW & RISER PIPE		304SS
CONICAL FILTER ELEMENT		
PERFORATED SCREEN		TBD
MESH SCREEN		TBD
SCREEN HEIGHT (IN)		31.23
NOTES		
CLEARANCE ABOVE STRAINER EQUAL TO SCREEN HEIGHT REQUIRED FOR SERVICE		

WARNING!
Exposure to high temperature water or equipment can cause serious injury or death. Proper thermal protection safeguards and PPE practices must be utilized.

Seller: _____

End User: _____

OUTLET, 8" Flange
w/ANSI Class 150
Hole Pattern

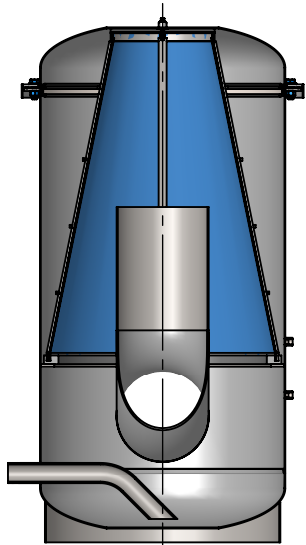

SECTION A-A

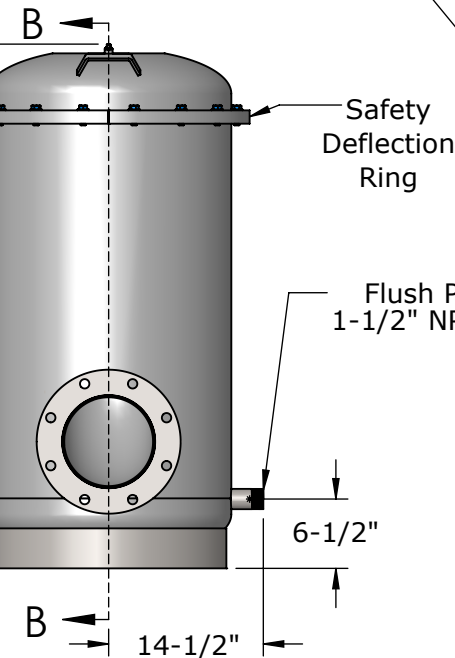
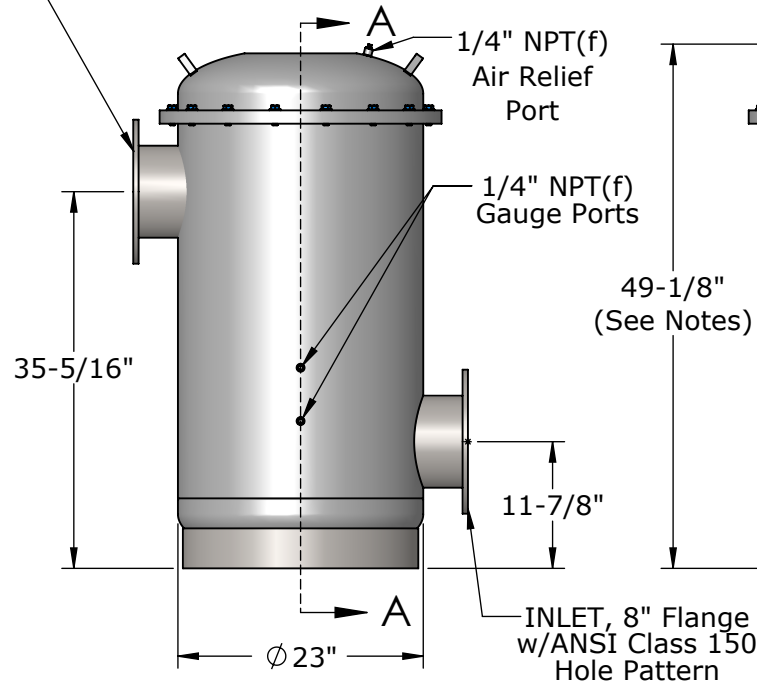

Conical Filter Element

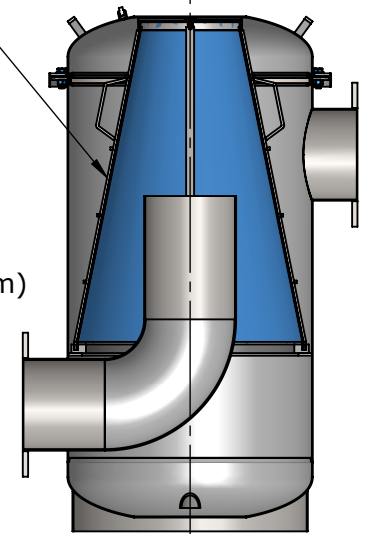

SECTION B-B



PRODUCT SPECIFICATION

MILLER LEAMAN
800 Orange Avenue, Daytona Beach, FL 32114

Dimensions are for reference only.

CUST. REF.	
PREV. MOD.	MLS-8-HT
ENG. REF.	ML20424-HT
DWG. DATE	3/14/22

SERIES:	MODEL:
CONFIGURATION:	MLS-08B-FS2-304E-M1