

GENERAL SPECIFICATIONS	
DESIGN FLOW (GPM)	200
MAX PRESSURE (PSI)	125
FILTRATION AREA (SQ IN)	200
DRY WEIGHT (LBS)	55
VOLUME (US GAL)	5
MAX TEMP (°F)	135

MATERIALS		
HOUSING / SCREEN FRAME		304SS
SCREEN		316SS
GASKETS		EPDM
ELBOW & RISER PIPE		304SS
CONICAL FILTER ELEMENT		
PERFORATED SCREEN		TBD
MESH SCREEN		TBD
SCREEN HEIGHT (IN)		15.16

RINSE NOZZLE REQUIREMENTS	
PRESSURE (PSIG)	60
FLOW (GPM)	28

NOTES		
CLEARANCE ABOVE STRAINER EQUAL TO SCREEN HEIGHT REQUIRED FOR SERVICE		

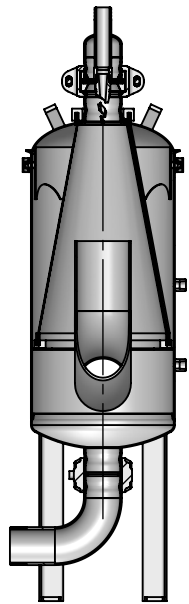

SECTION A-A

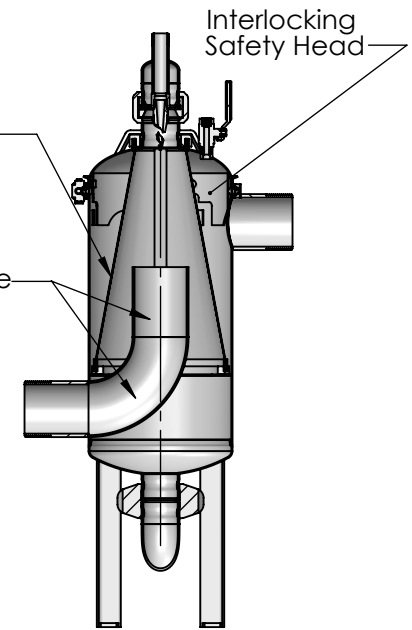
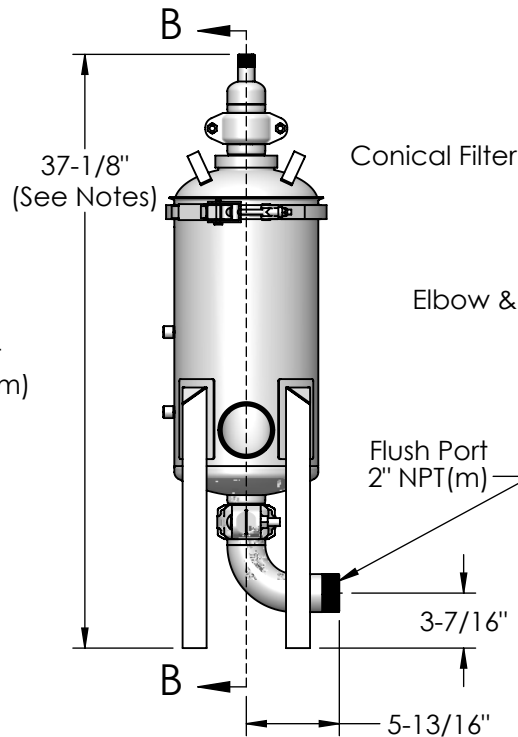
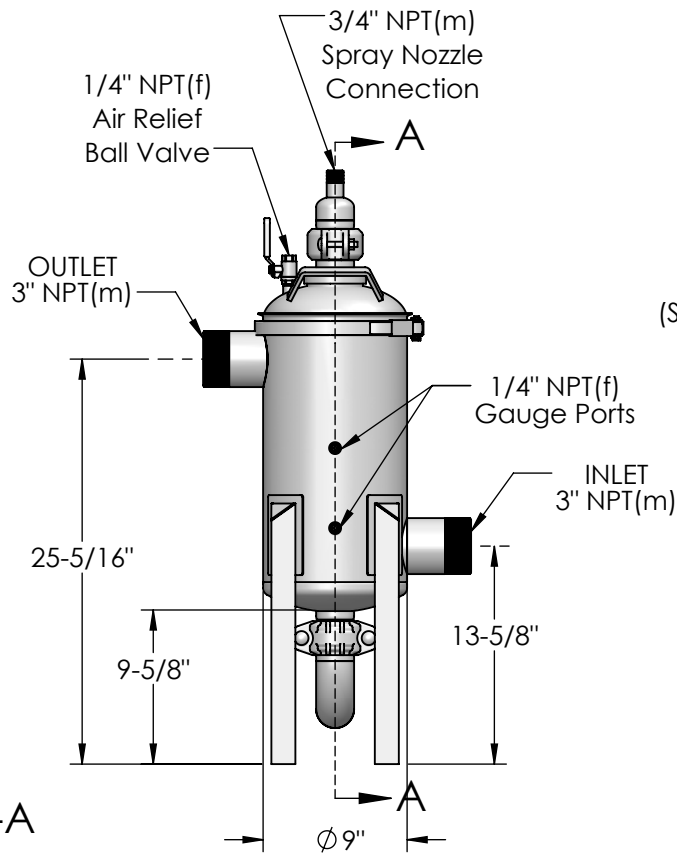

SECTION B-B



**PRODUCT SPECIFICATION**

**MILLER LEAMAN**  
800 Orange Avenue, Daytona Beach, FL 32114

Dimensions are for reference only.	
CUST. REF.	
PREV. MOD.	
ENG. REF.	ML20450-N-R
DWG. DATE	3/30/21

SERIES:	THOMPSON	MODEL:	STRAINER
CONFIGURATION:		MLS-03CR-NSR3-304E	