

GENERAL SPECIFICATIONS	
DESIGN FLOW (GPM)	350
MAX PRESSURE (PSI)	150
FILTRATION AREA (SQ IN)	367
DRY WEIGHT (LBS)	90
VOLUME (US GAL)	11
MAX TEMP (°F)	135

MATERIALS		
HOUSING / SCREEN FRAME		304SS
SCREEN		316SS
GASKETS		EPDM
ELBOW & RISER PIPE		304SS

CONICAL FILTER ELEMENT		
PERFORATED SCREEN		TBD
MESH SCREEN		TBD
SCREEN HEIGHT (IN)		15.91

RINSE NOZZLE REQUIREMENTS	
PRESSURE (PSIG)	60
FLOW (GPM)	28

NOTES		
CLEARANCE ABOVE STRAINER EQUAL TO SCREEN HEIGHT REQUIRED FOR SERVICE		

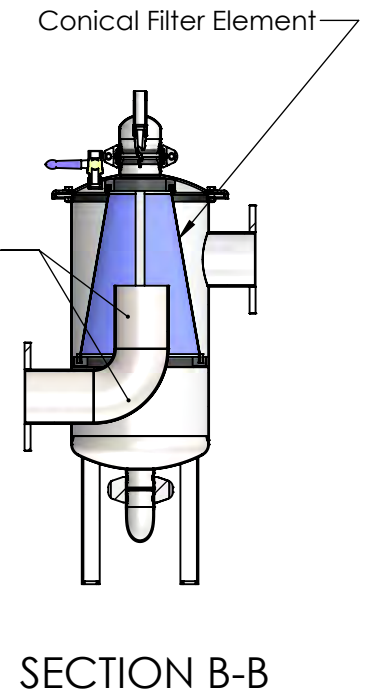
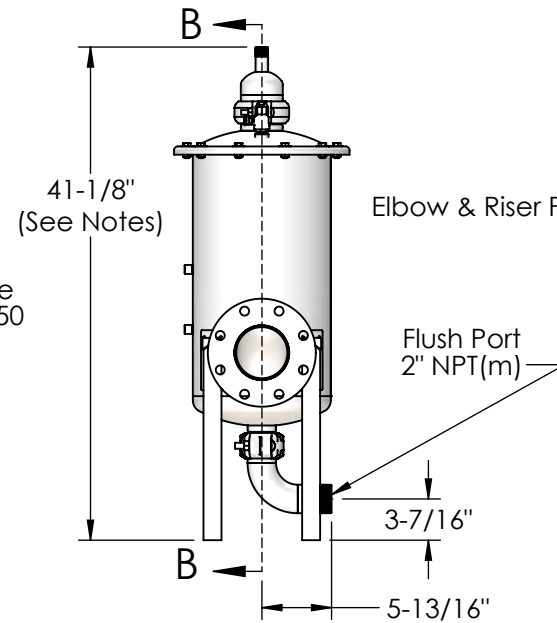
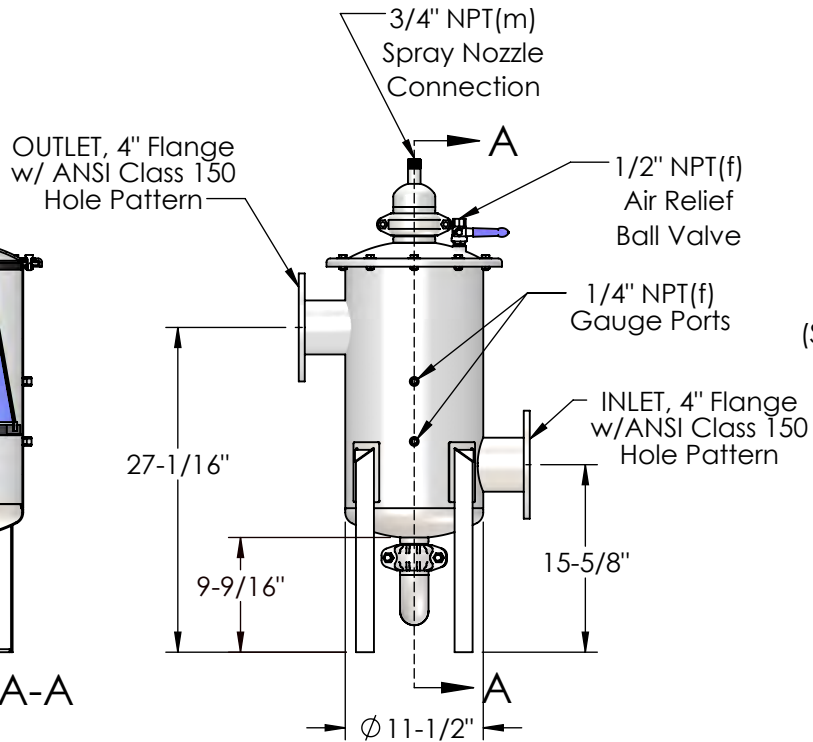
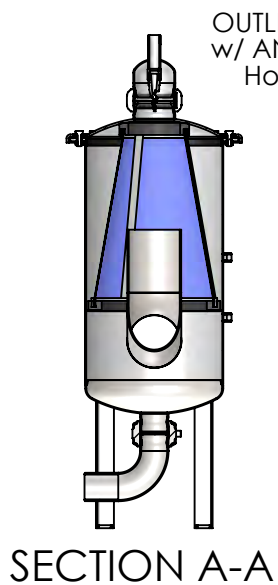

PRODUCT SPECIFICATION



800 Orange Avenue, Daytona Beach, FL 32114

Dimensions are for reference only.	
CUST. REF.	
PREV. MOD.	
ENG. REF.	ML20252-F-R
DWG. DATE	3/30/21
	SHEET 1 of 1

SERIES: THOMPSON	MODEL: STRAINER
CONFIGURATION: MLS-04BR-FSR3-304E	