

GENERAL SPECIFICATIONS	
DESIGN FLOW (GPM)	350
MAX PRESSURE (PSI)	125
FILTRATION AREA (SQ IN)	367
DRY WEIGHT (LBS)	91
VOLUME (US GAL)	11
MAX TEMP (°F)	135

RINSE NOZZLE REQUIREMENTS	
PRESSURE (PSIG)	60
FLOW (GPM)	28

MATERIALS		
HOUSING / SCREEN FRAME		304SS
SCREEN		316SS
GASKETS		EPDM
ELBOW & RISER PIPE		304SS
CONICAL FILTER ELEMENT		
PERFORATED SCREEN		TBD
MESH SCREEN		TBD
SCREEN HEIGHT (IN)		15.91
NOTES		
CLEARANCE ABOVE STRAINER EQUAL TO SCREEN HEIGHT REQUIRED FOR SERVICE		

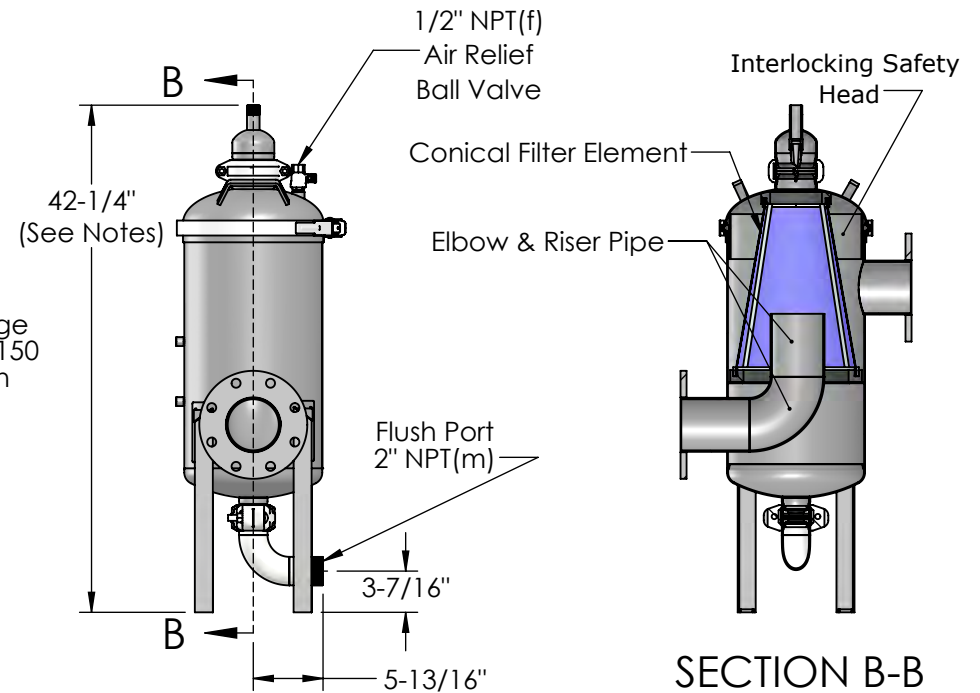
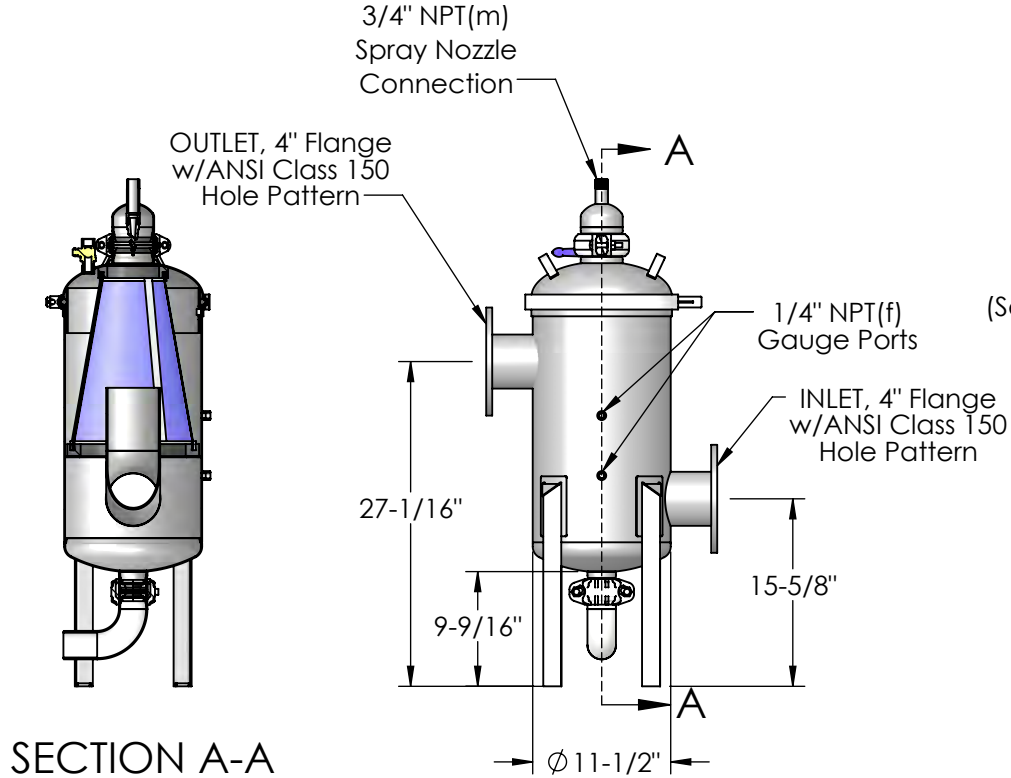

PRODUCT SPECIFICATION

MILLER LEAMAN
800 Orange Avenue, Daytona Beach, FL 32114

Dimensions are for reference only.	
CUST. REF.	
PREV. MOD.	
ENG. REF.	ML20398-F-R
DWG. DATE	3/30/21
	SHEET 1 of 1

SERIES: THOMPSON	MODEL: STRAINER
CONFIGURATION: MLS-04CR-FSR3-304E	