

Serial Number Location

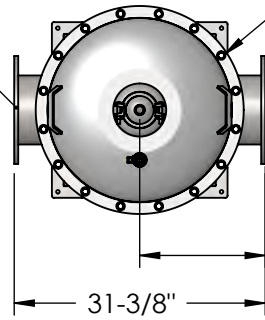

1/2-13 Grade 5 Bolts/Nuts & Stainless Steel Washers

15-11/16"

31-3/8"

GENERAL SPECIFICATIONS	
DESIGN FLOW (GPM)	1300
MAX PRESSURE (PSI)	150
FILTRATION AREA (SQ IN)	1559
DRY WEIGHT (LBS)	259
VOLUME (US GAL)	82
MAX TEMP (°F)	135

RINSE NOZZLE REQUIREMENTS	
PRESSURE (PSIG)	100
FLOW (GPM)	108

MATERIALS		
HOUSING / SCREEN FRAME		304SS
SCREEN		316SS
GASKETS		EPDM
ELBOW & RISER PIPE		304SS
CONICAL FILTER ELEMENT		
PERFORATED SCREEN		TBD
MESH SCREEN		TBD
SCREEN HEIGHT (IN)		31.23
NOTES		
CLEARANCE ABOVE STRAINER EQUAL TO SCREEN HEIGHT REQUIRED FOR SERVICE		

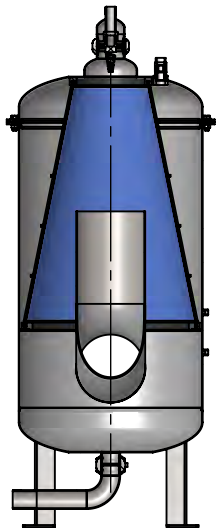

SECTION A-A

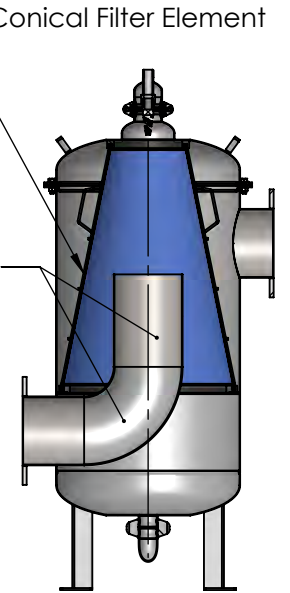
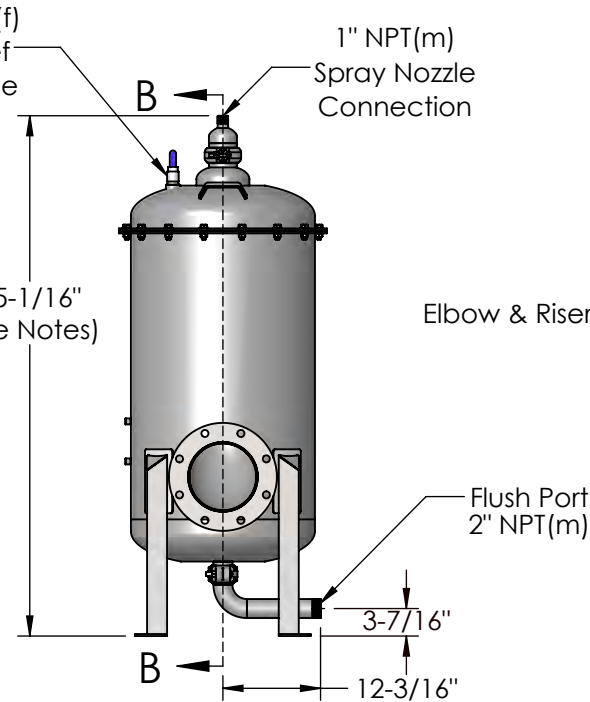
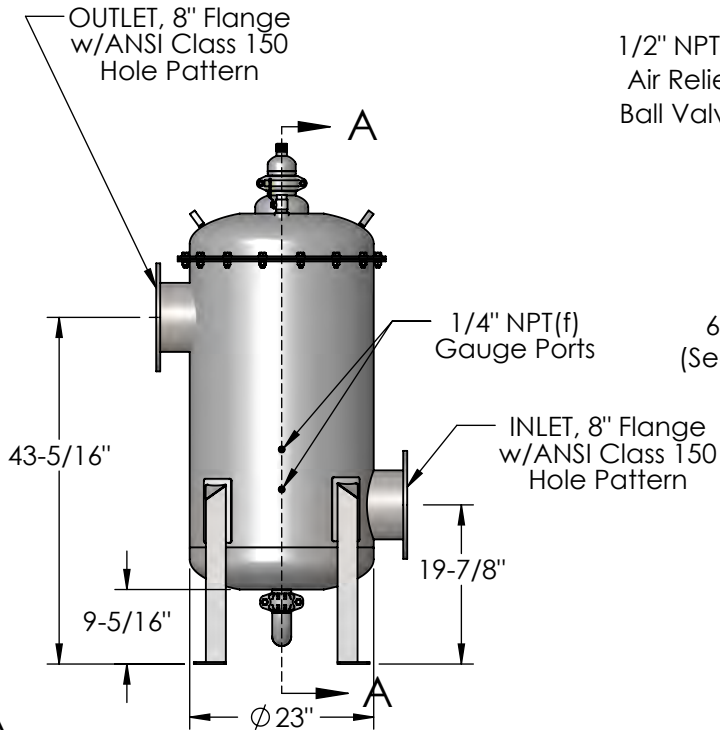

SECTION B-B



**PRODUCT SPECIFICATION**



800 Orange Avenue, Daytona Beach, FL 32114

Dimensions are for reference only.

CUST. REF.	
PREV. MOD.	
ENG. REF.	ML20424-F-R
DWG. DATE	3/30/21

SERIES:  
THOMPSON  
CONFIGURATION:

MODEL:  
STRAINER

MLS-08BR-FSR3-304E