

GENERAL SPECIFICATIONS	
DESIGN FLOW (GPM)	2000
MAX PRESSURE (PSI)	150
FILTRATION AREA (SQ IN)	2434
DRY WEIGHT (LBS)	465
VOLUME (US GAL)	170
MAX TEMP (°F)	135

MATERIALS	
HOUSING / SCREEN FRAME	304SS
SCREEN	316SS
GASKETS	EPDM
ELBOW & RISER PIPE	304SS

RINSE NOZZLE REQUIREMENTS	
PRESSURE (PSIG)	100
FLOW (GPM)	108

CONICAL FILTER ELEMENT	
PERFORATED SCREEN	TBD
MESH SCREEN	TBD
SCREEN HEIGHT (IN)	40.10

NOTES	
CLEARANCE ABOVE STRAINER EQUAL TO SCREEN HEIGHT REQUIRED FOR SERVICE	

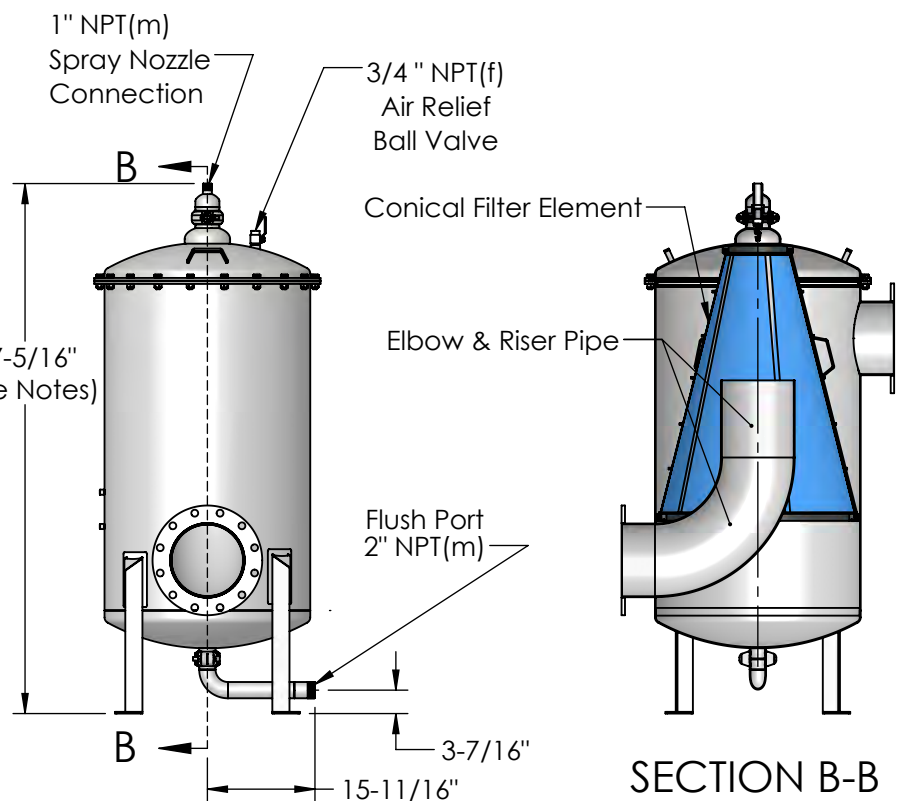
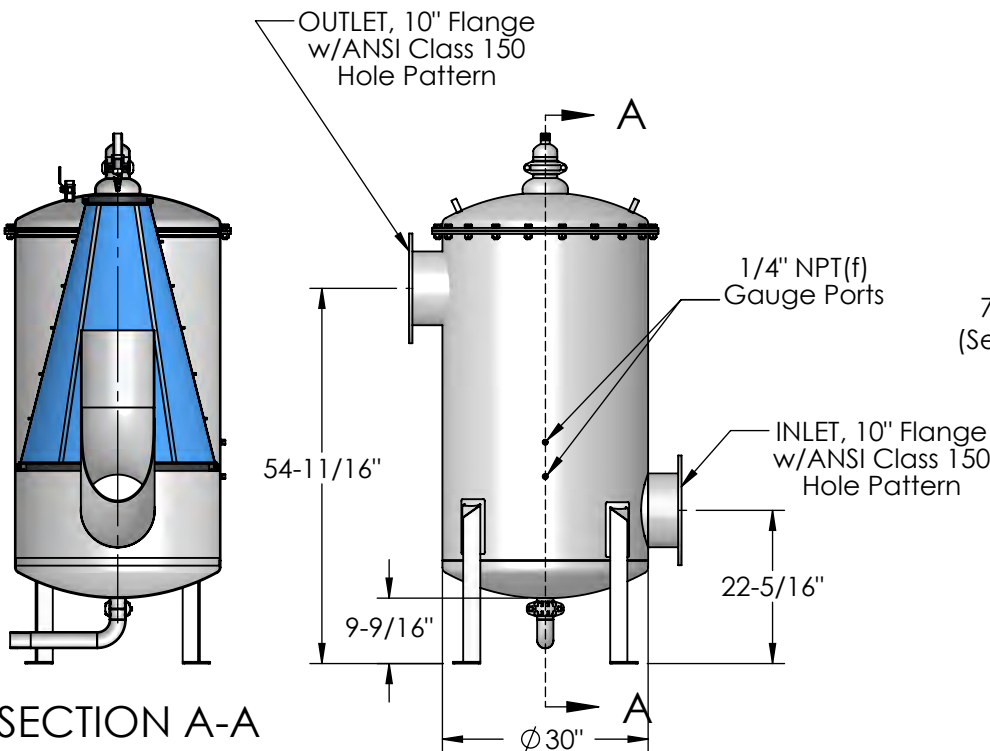

	<p align="center"><b>PRODUCT SPECIFICATION</b></p> <p align="center"><b>MILLER LEAMAN</b></p> <p align="center">800 Orange Avenue, Daytona Beach, FL 32114</p>	Dimensions are for reference only.		SERIES:	MODEL:
		CUST. REF.		THOMPSON	STRAINER
		PREV. MOD.		CONFIGURATION:	
		ENG. REF.	ML20438-F-R	MLS-10BR-FSR3-304E	
		DWG. DATE	3/30/21	SHEET 1 of 1	