

GENERAL SPECIFICATIONS	
DESIGN FLOW (GPM)	4000
MAX PRESSURE (PSI)	150
FILTRATION AREA (SQ IN)	2434
DRY WEIGHT (LBS)	568
VOLUME (US GAL)	184
MAX TEMP (°F)	135

RINSE NOZZLE REQUIREMENTS	
PRESSURE (PSIG)	100
FLOW (GPM)	108

MATERIALS		
HOUSING / SCREEN FRAME		304SS
SCREEN		316SS
GASKETS		EPDM
ELBOW & RISER PIPE		304SS
CONICAL FILTER ELEMENT		
PERFORATED SCREEN		TBD
MESH SCREEN		TBD
SCREEN HEIGHT (IN)		40.10
NOTES		
CLEARANCE ABOVE STRAINER EQUAL TO SCREEN HEIGHT REQUIRED FOR SERVICE		

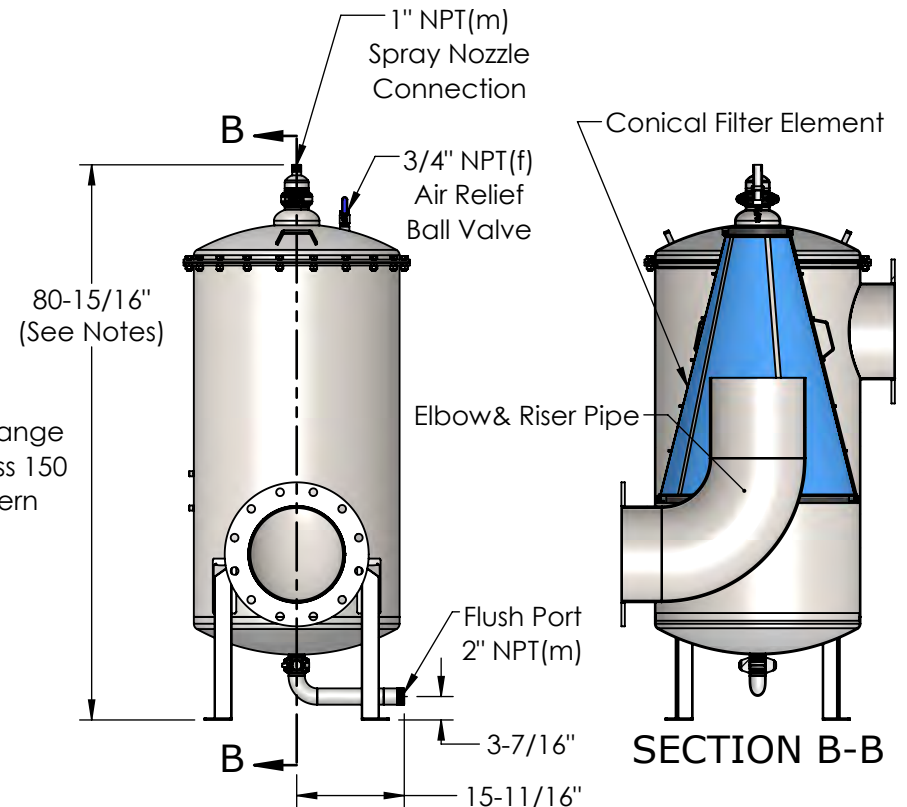
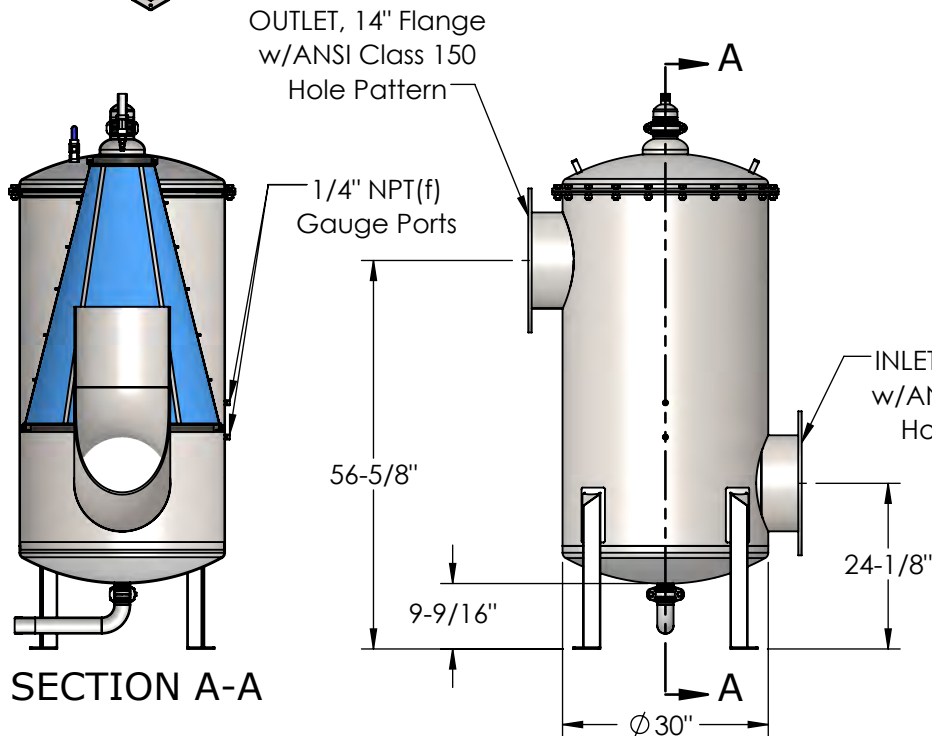

**PRODUCT SPECIFICATION**

**MILLER LEAMAN**  
800 Orange Avenue, Daytona Beach, FL 32114

Dimensions are for reference only.

CUST. REF.	
PREV. MOD.	
ENG. REF.	ML22410-F-R
DWG. DATE	3/30/21

SERIES:  
THOMPSON  
CONFIGURATION:

MODEL:  
STRAINER

MLS-14BR-FSR3-304E